

Piet Hein

LIGHTNING



2023



Love while you've got
love to give.
Live while you've got
life to live.

SUPERCUBE

150 - 200



Piet Hein

SUPERCUBE

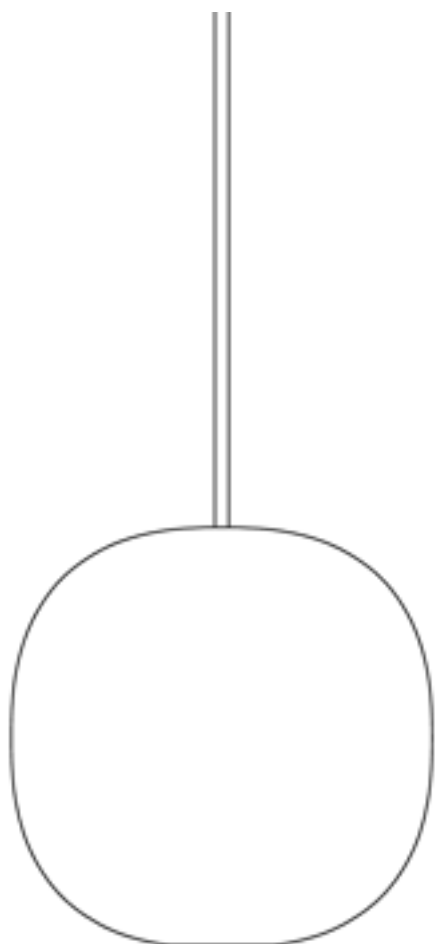

FAKTA

MOUTH-BLOWN OPAQUE GLASS WITH 3 METRE FABRIC-COVERED CORD.

SIZES

150P - H: 150MM, Ø:150MM, MAX 42W G9
200P - H: 200MM Ø:200MM, MAX 42W G9

COLOUR

OPAQUE GLASS WITH A CHOICE OF COLOUR OPTIONS. FABRIC COVERED CORD AVAILABLE IN WHITE OR BLACK.

BACKGROUND

THE SUPERCUBE, LIKE THE SUPERELLIPSE®, IS AN EXAMPLE OF PIET HEIN'S FASCINATION WITH DESIGN AND GEOMETRY. THE SUPERCUBE IS THE THREE-DIMENSIONAL VERSION OF THE SUPERCIRCLE, WHICH IS BASED ON THE SAME SHAPE AS THE SUPERELLIPSE®. IF THE SHAPE LOOKS FAMILIAR, IT MIGHT BE BECAUSE THE DANISH FURNITURE MAKERS, FRITZ HANSEN, PRODUCE A TABLE BASED ON THE SAME PIET HEIN DESIGN.

CORD COLOR

WHITE



BLACK



SUPEREGG

150 - 200 - 300



Piet Hein

SUPEREGG

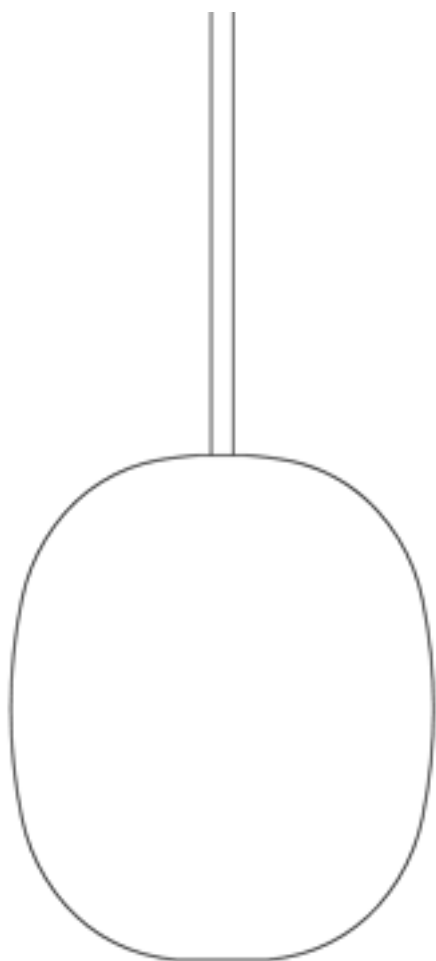

FACTS

MOUTH-BLOWN OPAQUE GLASS WITH 3 METRE FABRIC-COVERED CORD.

SIZES

150P - H: 150MM, Ø:125MM, MAX 42W G9
200P - H: 200MM Ø:168MM, MAX 42W G9
300P - H: 320MM, Ø: 250MM, MAX 105W E27

COLOR

OPAQUE GLASS WITH A CHOICE OF COLOUR OPTIONS. FABRIC COVERED CORD AVAILABLE IN WHITE OR BLACK.

BACKGROUND

THE SUPEREGG LAMP IS A DESIGN BY PIET HEIN BASED ON HIS ICONIC SUPERELLIPSE®. THE SMALL OPENING AT THE BASE OF THE LAMP HIDES BOTH THE BULB AND SOCKET, ENSURING THAT THE BEAUTIFULLY LUMINOUS SUPEREGG EASILY INTEGRATES INTO ANY INTERIOR DESIGN. BASED ON THE CLEAN, GEOMETRIC SHAPE OF THE SUPERELLIPSE®, THE SUPEREGG'S ELEGANT SIMPLICITY AND SOFT LIGHT MAKES IT IDEAL FOR HANGING ANYWHERE WITHIN THE HOME.

CORD COLOR

WHITE



BLACK



RED



BIKUBEN

180 - 290



Piet Hein

BIKUBEN

FACTS

MOUTH-BLOWN OPAQUE GLASS WITH 3 METRE FABRIC-COVERED CORD.

SIZES

180P - H: 160MM, Ø:177MM, MAX 40W E14
290P - H: 260MM Ø:288MM, MAX 40W E27

COLOR

OPAQUE GLASS WITH A CHOICE OF COLOUR OPTIONS. FABRIC COVERED CORD AVAILABLE IN WHITE OR BLACK.

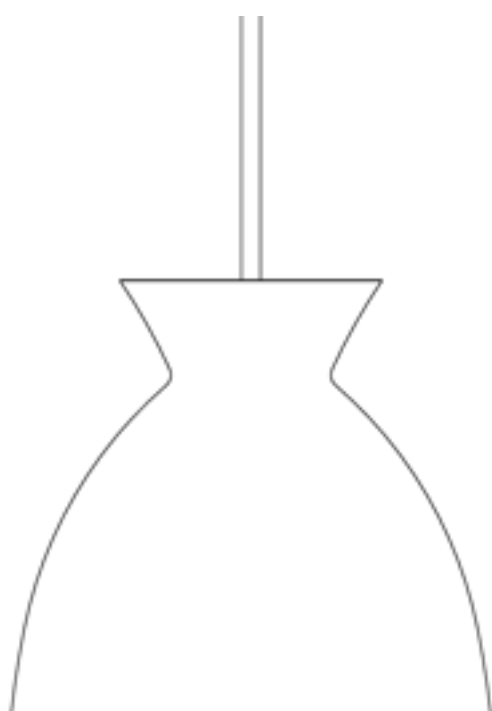

HISTORIE

THE BIKUBEN STARTED OUT IN 1979 IN THE FORM OF A SUGGESTION FROM PIET HEIN FOR WORKPLACE LIGHTING FOR THE DANISH SAVINGS BANK, BIKUBEN (HE ALSO GAVE THE BANK - AND THE LAMP - AN ADDED BONUS, THE SLOGAN, "LET BIKUBEN BE BY YOUR SIDE"). THE LAMP WAS NEVER SOLD COMMERCIALY AT THE TIME, AND IT WAS NOT UNTIL 2018 THAT IT WAS ADDED TO OUR LIGHTNING UNIVERSE, ITS UNIQUE HIVE SHAPE THE RESULT OF LIGHTING AND AESTHETIC DEMANDS.

CORD COLOR

WHITE



BLACK



FLORA FOLIO



Piet Hein

FLORA FOLIO

FACTS

LACQUERED ALUMINIUM SHADES; MATTE WHITE ON THE INSIDE AND SEMI-GLOSSY ON THE OUTSIDE. MOUNTED ON EXTRUDED ALUMINIUM ARMS.

SIZE

H: 650MM Ø:600MM, MAX 200W E27

COLOR

WHITE WITH 6 METRES OF BLACK TEXTILE CORD.

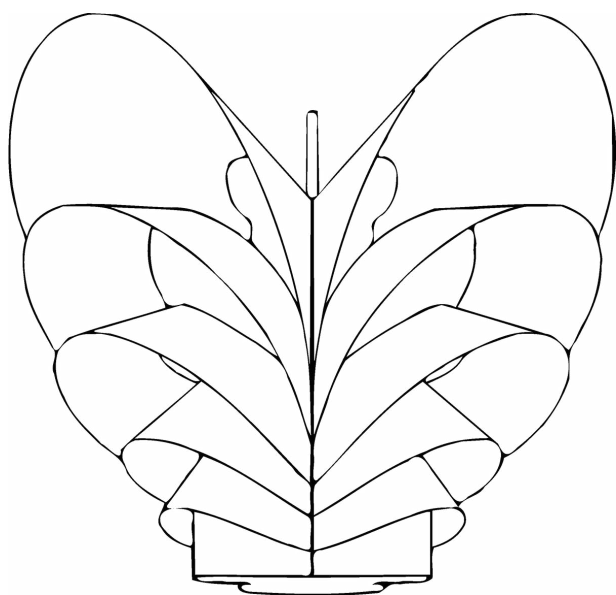

BACKGROUND

DESIGNED BY PIET HEIN IN 1969, THE FLORA FOLIO IS AN UNUSUALLY ATTRACTIVE LAMPSHADE IDEAL FOR LARGER ROOMS. FLOWER-LIKE, AND WITH PERFECT DISTRIBUTION OF LIGHT, THE LEAVES OF THE SHADE FOLD OUT CREATING THE BEAUTIFUL CHARACTERISTIC FORM OF THE SUPERELLIPSE®. MATTE ON THE INSIDES AND WITH A SEMI-GLOSS FINISH ON THE OUTSIDE, THE LACQUERED WHITE LEAVES ARE MOUNTED ON EXTRUDED ALUMINIUM ARMS, WHICH ARE ALSO SHAPED IN THE FORM OF THE SUPERELLIPSE®. A LUMINOUS UNICUM.

CORD COLOR

BLACK



FUNCO



Piet Hein

FUNCO

FACTS

WHITE CANVAS SHADE WITH REFLECTING INNER SURFACE. STAINLESS STEEL FOOT.

SIZE

H: 550MM Ø: 320MM
FOD Ø:220MM MAX 20W E27

COLOR

WHITE WITH 2.3 METER BLACK TEXTILE CORD.

BACKGROUND

DESIGNED IN 1933, THE FUNCO MADE ITS FIRST APPEARANCE AT PEIN HEIN'S 1934 SPRING SHOW. THE SHADE CAN BE TILTED TO HELP SPREAD LIGHT AS REQUIRED. DUE TO THE MATERIAL USED IN ITS CONSTRUCTION, THE FUNCO'S SHADE IS WHITE WHEN THE LAMP IS OFF AND DISPLAYS A BRIGHT AND ATTRACTIVE BIFOLD EFFECT WHEN SWITCHED ON. THE CLASSIC DESIGN IS COMPLETED BY THE SUPEEGG SHAPED CORD END AND THE GEOMETRIC CURVE OF THE FOOT, WHICH ELEGANTLY CONCEALS THE LAMP'S CABLE.

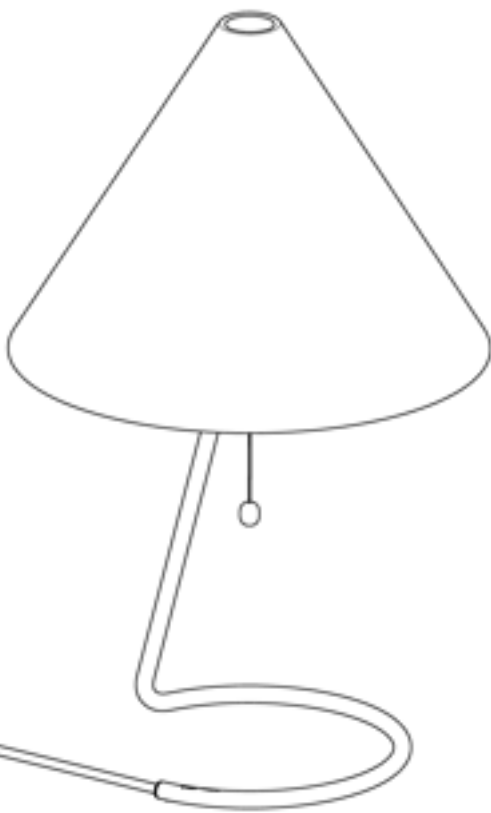

CORD COLOR

BLACK



SUPER

90 - 115 - 215



Piet Hein

SUPER

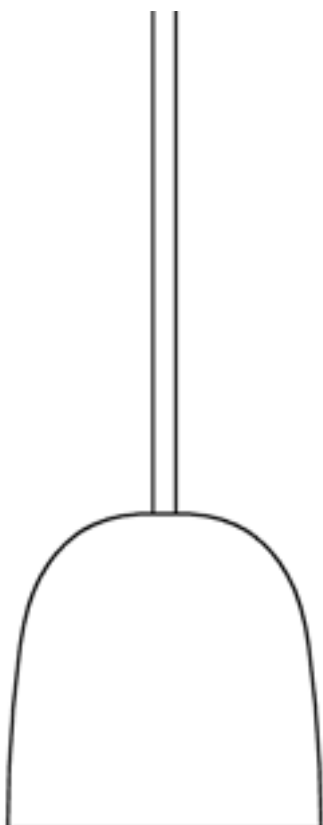

FACTS

FROSTED GLASS WITH A 3 METRE FABRIC-COVERED CORD.

SIZES

90P - H: 93MM, Ø:90MM, MAX 42W G9

115P - H: 119MM Ø:115MM, MAX 42W G9

215P - H:174MM, Ø: 216, MAX 60W E27

COLORS

FROSTED GLASS WITH OPTIONAL COLOR TEXTILE CORD IN RED, WHITE OR BLACK (3 METERS).

SUPER 215 IS ALSO AVAILABLE WITH A WHITE METAL SCREEN.

BACKGROUND

THE SPLENDIDLY NAMED SUPER, ORIGINALLY DESIGNED IN 1975, IS YET ANOTHER PRODUCT OF PIET HEIN'S PLAYFUL EXPERIMENTS WITH GEOMETRY AND REFRACTING AND REFLECTING CURVES THE COMBINATION OF OPEN BOTTOM AND DIFFUSING OPAQUE GLASS CREATES BOTH AN INTENSE POOL OF LIGHT UNDER THE LAMP, AS WELL AS EXCELLENT, GLARE-FREE LIGHTING FOR THE REST OF THE ROOM.

CORD COLOR

WHITE



BLACK



RED



RA TABLELAMP

250 - 400



Piet Hein

RA TABLE LAMP

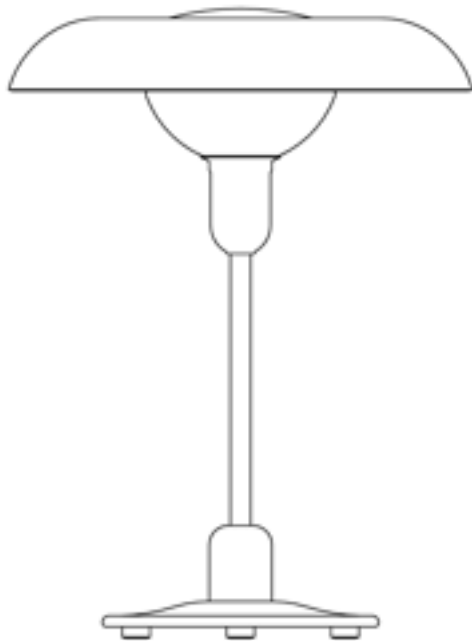

FACTS

THE SHADE IS MADE UP OF TWO PARTS THAT EVENLY DISTRIBUTE LIGHT WITHOUT ANY GLARE. INCLUDES 2 METRE BLACK CORD WITH SWITCH.

SIZES

250 - H: 336MM, Ø:250MM, MAX 40W G9
400 - H: 527MM Ø:415MM, MAX 60W E27

COLORS

BLACK METAL, WHITE METAL, CHROME OR OPAQUE GLASS.
ALL SUPPLIED WITH BLACK CORD AND CHROME FRAME.

BACKGROUND

DESIGNED IN 1931, THE RA TABLE LAMP IS MADE UP OF TWO PARTS THAT EVENLY DISTRIBUTE LIGHT WITHOUT ANY GLARE WHILE ENSURING THAT ALMOST NO LIGHT IS LOST. AS WITH ALL HIS DESIGNS, PRECISE MATHEMATICAL CALCULATIONS LAY BEHIND PIET HEIN'S GOAL OF DESIGNING OBJECTS AS NEAR TO PERFECTION AS POSSIBLE. THE GLASS SHADED RA CASTS A SOFT, ROOM FILLING LIGHT, WHILE THE METAL SHADED VERSION CREATES A FINE, INDIRECT LIGHT.

COLORS AND MATERIALS

OPAQUE GLASS



BLACK METAL



WHITE METAL



CHROME



RA PENDANT

250 - 400



Piet Hein

RA PENDANT

FACTS

THE SHADE IS MADE UP OF TWO PARTS THAT EVENLY DISTRIBUTE LIGHT WITHOUT ANY GLARE. INCLUDES 3 METRE BLACK CORD.

SIZES

250 - H: 181MM, Ø:250MM, MAX 40W G9
400 - H: 289MM Ø:415MM, MAX 75W E27

FARVER

BLACK METAL, WHITE METAL AND CHROME.
COMES WITH BLACK CORD AND CHROME FRAME.

BACKGROUND

DESIGNED IN 1931, THE RA TABLE LAMP IS MADE UP OF TWO PARTS THAT EVENLY DISTRIBUTE LIGHT WITHOUT ANY GLARE WHILE ENSURING THAT ALMOST NO LIGHT IS LOST. AS WITH ALL HIS DESIGNS, PRECISE MATHEMATICAL CALCULATIONS LAY BEHIND PIET HEIN'S GOAL OF DESIGNING OBJECTS AS NEAR TO PERFECTION AS POSSIBLE.

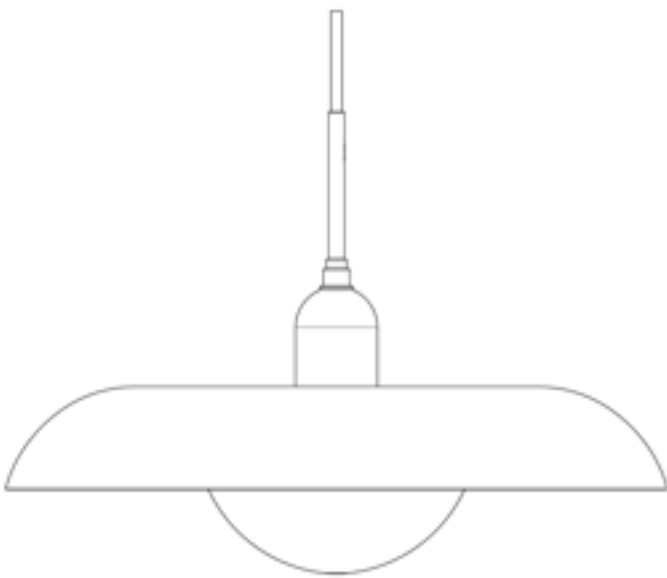

COLORS AND MATERIALS

BLACK METAL



WHITE METAL



CHROME



SINUS

330 - 440 - 550



Piet Hein

SINUS

FACTS

FROSTED, WHITE OPAQUE GLASS. INCLUDES 4 METRE FABRIC-COVERED CABLE AND 11 CM DIAMETER CANOPY TO COVER THE LED TRANSFORMER.

SIZES

330P - H:70MM, Ø:330MM, LED 7,5 WATT
440P - H:78MM, Ø:440MM, LED 10,5 WATT
550P - H:79MM, Ø:550MM, LED 10,5 WATT

COLORS

FROSTED OPAQUE GLASS WITH WHITE TEXTILE CORD.

BACKGROUND

WHEN PIET HEIN DESIGNED THE SINUS IN 1967, THE GOAL WAS TO PRODUCE A LAMP BASED ON THE SHAPE OF THE SINE WAVE, A MATHEMATICALLY HARMONIOUS FORM THAT IS ALSO IDEAL SEEN FROM THE PERSPECTIVE OF LIGHTING TECHNOLOGY. THE CURVED FORMS OF THE SHADE ENSURE THAT THE LIGHT IS BRIGHT WHERE NEEDED, GLARE-FREE AT EYE-LEVEL AND ALLURINGLY DISPERSED AROUND THE ROOM. A BEAUTIFUL FLOATING SCULPTURE, THE SINUS IS LIGHT, PERFECTLY DISTRIBUTED.



CORD COLOR

WHITE



SINUS TABLELAMP

330 - 440



Piet Hein

SINUS TABLELAMPE

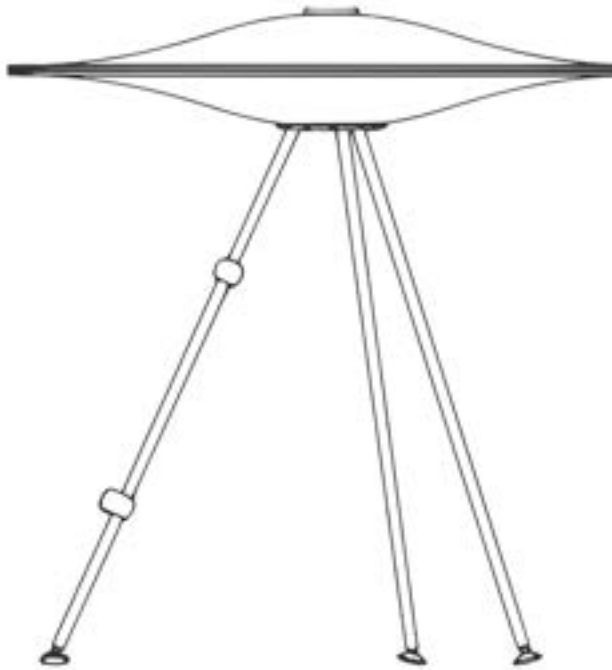

FACTS

DESIGNED IN 1979. FROSTED WHITE OPAQUE GLASS SHADE WITH STAINLESS STEEL LEGS. 2.5M TEXTILE CORD WITH SWITCH/DIMMER.

SIZES

330 - H: 372MM, Ø:330MM MAX 40W G9
440 - H: 443MM, Ø:440MM MAX 40W G9

COLOR

FROSTED WHITE OPAQUE GLASS WITH OPTIONAL RED OR BLACK TEXTILE CORD.

BACKGROUND

WHEN PIET HEIN DESIGNED THE SINUS IN 1967, THE GOAL WAS TO PRODUCE A LAMP BASED ON THE SHAPE OF THE SINE WAVE, A MATHEMATICALLY HARMONIOUS FORM THAT IS ALSO IDEAL SEEN FROM THE PERSPECTIVE OF LIGHTING TECHNOLOGY. THE CURVED FORMS OF THE SHADE ENSURE THAT THE LIGHT IS BRIGHT WHERE NEEDED, GLARE-FREE AT EYE-LEVEL AND ALLURINGLY DISPERSED AROUND THE ROOM. A BEAUTIFUL FLOATING SCULPTURE, THE SINUS IS LIGHT, PERFECTLY DISTRIBUTED.

CORD COLOR

BLACK



RED



SINUS FLOORLAMP

SINUS 440



Piet Hein

SINUS FLOORLAMP



FACTS

DESIGNED IN 1979. FROSTED WHITE OPAQUE GLASS SHADE WITH STAINLESS STEEL LEGS. 3M TEXTILE CORD WITH SWITCH/DIMMER.

SIZE

440 - H: 1249MM, Ø:440MM, B: 550MM MAX
40W G9

COLOR

FROSTED WHITE OPAQUE GLASS WITH OPTIONAL RED OR BLACK TEXTILE CORD.

BACKGROUND

WHEN PIET HEIN DESIGNED THE SINUS IN 1967, THE GOAL WAS TO PRODUCE A LAMP BASED ON THE SHAPE OF THE SINE WAVE, A MATHEMATICALLY HARMONIOUS FORM THAT IS ALSO IDEAL SEEN FROM THE PERSPECTIVE OF LIGHTING TECHNOLOGY. THE CURVED FORMS OF THE SHADE ENSURE THAT THE LIGHT IS BRIGHT WHERE NEEDED, GLARE-FREE AT EYE-LEVEL AND ALLURINGLY DISPERSED AROUND THE ROOM. A BEAUTIFUL FLOATING SCULPTURE, THE SINUS IS LIGHT, PERFECTLY DISTRIBUTED.

CORD COLOR

BLACK



RED



Piet Hein

PIET HEIN TRADING APS
MANDALVÆNGET 5
5500 MIDDELFART
DANMARK

CVR: 27 05 27 38

CUSTOMER SERVICE

+ 45 63 40 40 80
INFO@PIETHEIN.COM