

Piet Hein

ACCESSORIES COLLECTION





Love is like
a pineapple
sweet and
undefineable.

Piet Hein

SUPER

VASE



Piet Hein

SUPER VASE

FACTS

Superelliptical vase made of mouth-blown glass.

SIZES

16 cm - 20 cm - 25 cm - 30 cm - 50 cm

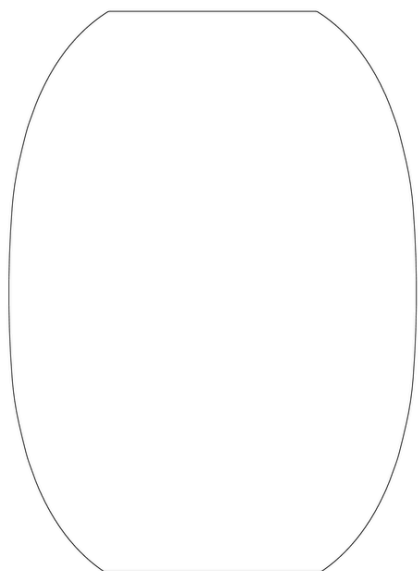

COLOURS

Clear, opal, grey and black.

BACKGROUND

The SUPER vase is designed after Piet Hein's Superellipse® and, with its simple expression, is a natural part of the decor. The vase is mouth-blown, making each vase unique, although they all share the soft expression of the superellipse. Since the vase is mouth-blown, small air bubbles may occur, adding character to the vase. We discard vases with significant air bubbles.

COLOURS

CLEAR



OPAL



GREY



BLACK



TWISTER

VASE



Piet Hein

TWISTER VASE

FACTS

Mouth-blown glass vase with a twist.

SIZES

16 cm
24 cm

COLOURS

Clear, opal and black.

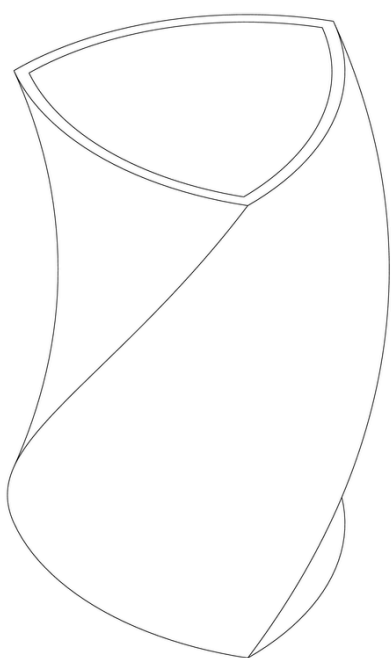

BACKGROUND

Piet Hein was often inspired by people, nature, and architecture. Architecture, in particular, was a significant source of inspiration for the TWISTER vase, which Piet Hein conceived after closely studying Copenhagen's old city hall, now known as the Copenhagen City Court at Nytorv. He was captivated by the columns in front of the main entrance and the idea of "twisting" three of them together. This idea eventually became the TWISTER vase, a remarkable sculpture and a beautiful vase for flowers and branches. Like the SUPER vase, the TWISTER vase is mouth-blown.

COLOURS

CLEAR



OPAL



BLACK



CANDLEHOLDERS

MARS - VENUS - JUPITER - SATURN



Piet Hein

MARS - VENUS - JUPITER - SATURN

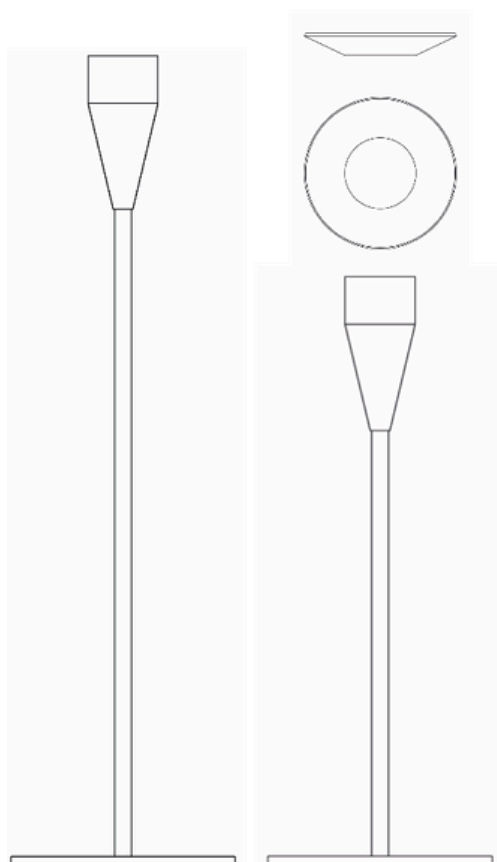

FACTS

Manufactured in stainless steel and fits standard 22 mm candles. Grease Guards can be purchased separately.

SIZES

Mars 15 cm
Venus 21 cm
Jupiter 29 cm
Saturn 36 cm

COLOURS

Steel
Mat black
Brass

BACKGROUND

Piet Hein's well-known and simple candleholders followed his seven-armed candelabra, Great Bear. Since Great Bear was named after the constellation, Piet Hein looked to the planets when naming the freestanding single candleholders. The candleholders can stand individually or as a decorative group across different sizes, creating an eye-catching dynamic.

COLOURS

MAT BLACK

STEEL

BRASS

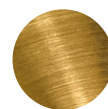
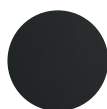

SOUTHERN CROSS

CANDELABRA



Piet Hein

SOUTHERN CROSS

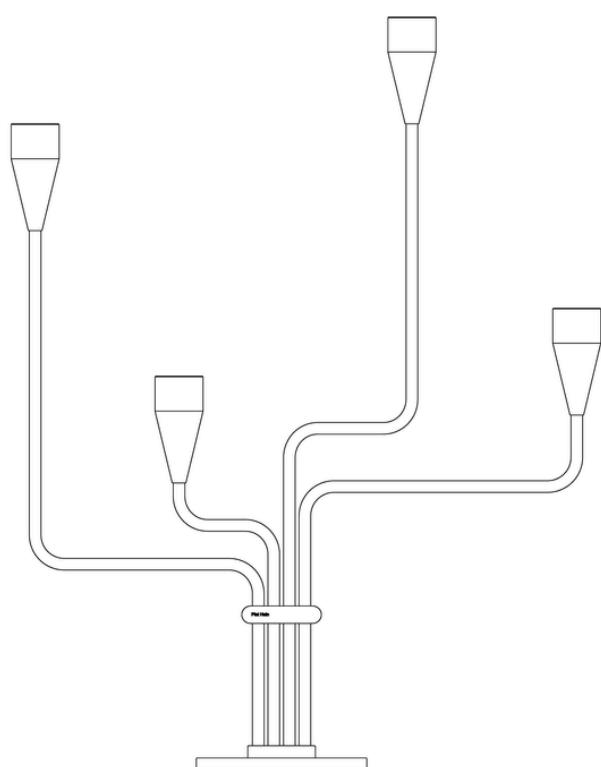

FACTS

The Southern Cross can hold four standard 22 mm candles, which can be placed either in a line or staggered in the adjustable arms. Grease Guards can be purchased separately.

SIZE

Height: 38 cm

COLOURS

Stainless steel
Mat black

BACKGROUND

The Southern Cross is a constellation in the southern night sky and, in Piet Hein's design, a four-armed, timeless candleholder. Like its "big brother," Great Bear, it has flexible arms. This means that the Southern Cross can stand perfectly straight on the table for lunch, fitting into a modern, sleek setting, and then, for the evening meal, it can shine from various "angled" positions, adding a relaxed ambiance.

COLOURS

STEEL



MAT BLACK



GREAT BEAR

CANDELABRA



Piet Hein

GREAT BEAR

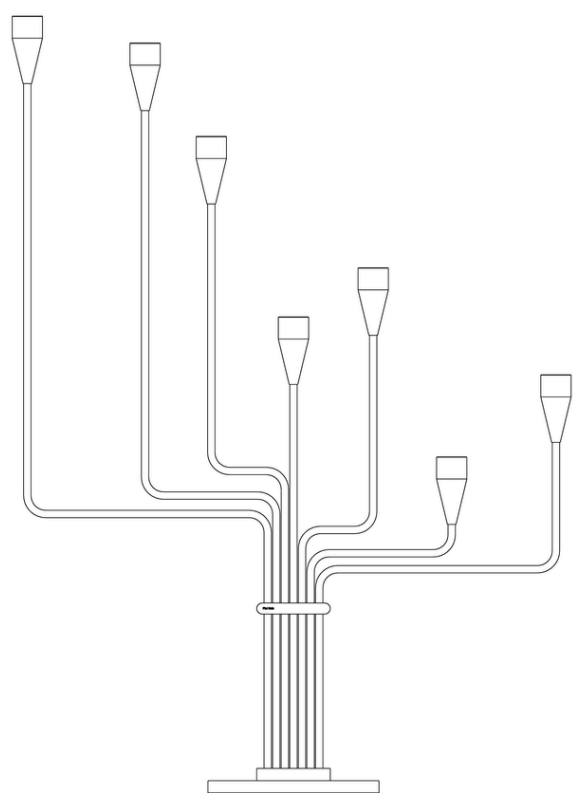

FACTS

The Great Bear can hold seven standard 22 mm candles, which can be placed either in a line or staggered in the adjustable arms. Grease Guards can be purchased separately.

SIZE

Height: 63 cm

COLOURS

Stainless steel
Mat black
Brass

BACKGROUND

The idea for the Great Bear came to Piet Hein in 1944 in Argentina, where he was living at the time and came to miss the northern night sky. Piet Hein began experimenting with transferring the constellation to a seven-branched candelabra that could shine anywhere in the world. After returning to Denmark, one prototype was made, followed by many more. Today, the Great Bear is still ideal for both creating a cosmic, pleasant atmosphere and being a sculptural piece of solid Danish design in the home. The seven arms are flexible, so the candles can shine in a row or from multiple angles.

COLOURS

MAT BLACK

STEEL

BRASS

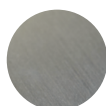
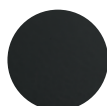

MULTI
CANDLEHOLDER



Piet Hein

MULTI CANDLEHOLDER

FACTS

Solid super-egg in brushed stainless steel.

SIZE

Height: 6 cm

COLOUR

Steel

BACKGROUND

Inspired by his iconic Superellipse®, Piet Hein created a multifunctional candleholder. The candleholder can be used with both tealights and classic 22 mm candles.

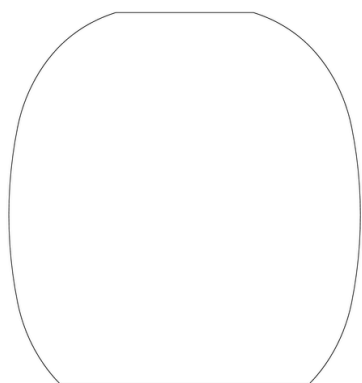

COLOUR

STEEL



ORION

WALL-MOUNTED CANDLEHOLDER



Piet Hein

ORION WALL-MOUNTED CANDLEHOLDER

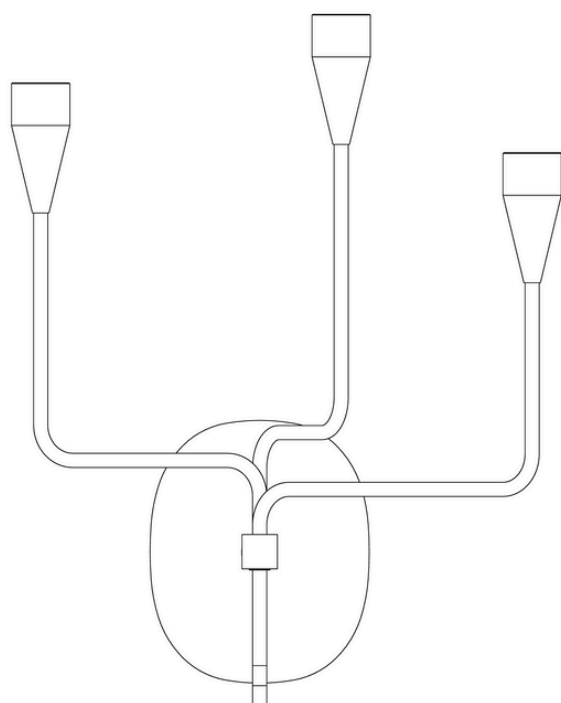

FACTS

The wall plate of the candleholder has a Superellipse® shape. It is mounted with hidden screws and is made of stainless steel. Fits 22 mm candles. Grease Guards can be purchased separately.

SIZE

Height: 30 cm
Depth: max. 20 cm and min. 6 cm
Width: max. 26,5 cm and min. 9,5 cm

MATERIAL

Stainless steel

BACKGROUND

The night sky fascinated Piet Hein to such an extent that many of his designs were influenced by it. Orion is no exception, where the constellation served as the inspiration for both its form and name. The lights on Orion's three adjustable arms contribute to creating a light and floating effect in any room.

COLOUR

STEEL



MERCURY

WALL-MOUNTED CANDLEHOLDER



Piet Hein

MERCURY WALL-MOUNTED CANDLEHOLDER

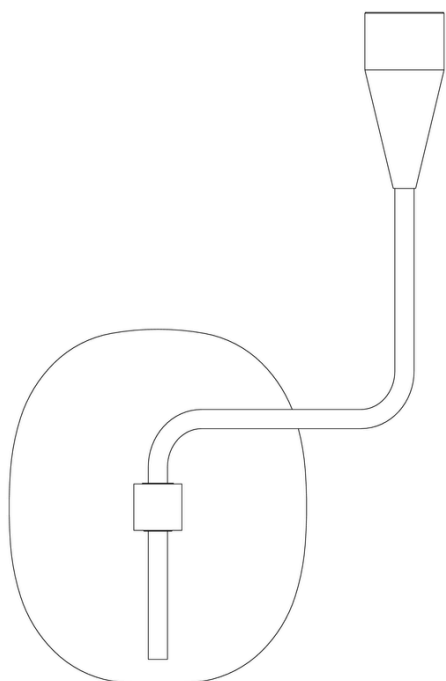

FACTS

The wall plate of the candleholder has a Superellipse® shape. It is mounted with hidden screws and is made of stainless steel. Fits 22 mm candles. Grease Guards can be purchased separately.

SIZE

Height: 20 cm
Depth: max. 12 cm and min. 3 cm.
Width: max. 15 cm and min. 9,5 cm

MATERIAL

Stainless steel

BACKGROUND

The night sky fascinated Piet Hein to such an extent that many of his designs were influenced by it. Mercury is no exception, with the planet serving as the inspiration for both its form and name. The light on Mercury's adjustable arm helps to create a light and floating effect in any room.

COLOUR

STEEL

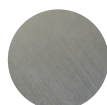

MAXI CANDLEHOLDERS

MARS - VENUS - JUPITER - SATURN



Piet Hein

MAXI

MARS - VENUS - JUPITER - SATURN

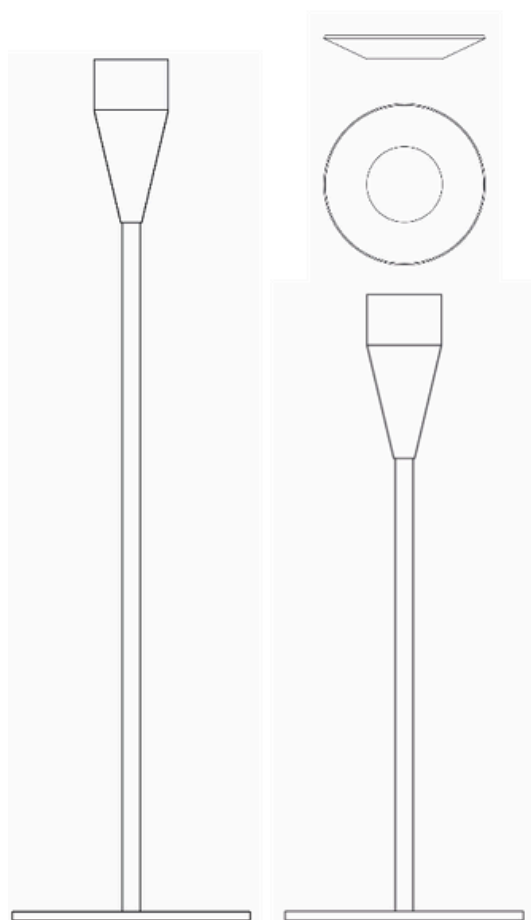

FACTS

Made of stainless steel.
Grease Guards can be purchased separately.

SIZES

Mars 32 cm
Venus 47,5 cm
Jupiter 65 cm
Saturn 80,5 cm

COLOURS

Steel
Mat black
Brass

BACKGROUND

The Maxi candleholders are the classic planetary candleholders that have been enlarged. The result is four substantial floor-standing candleholders that give the impression of having torches indoors. The candleholders create a cozy atmosphere similar to a fireplace, and because they hold large candles, they provide long-lasting illumination..

COLOURS

MAT BLACK

STEEL

BRASS

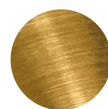

G R E A T B E A R

M A X I



Piet Hein

GREAT BEAR MAXI

FACTS

Made of stainless steel. Grease Guards can be purchased separately.

SIZE

Height: 130 cm

COLOUR

Stainless steel

BACKGROUND

The idea for the Great Bear came to Piet Hein in 1944 in Argentina, where he was living at the time and came to miss the northern night sky. Piet Hein began experimenting with transferring the constellation to a seven-armed candelabrum that could shine anywhere in the world. After returning to Denmark, one prototype was made, followed by many more. The Great Bear Maxi, with its long arms and large candles, creates a warm and attractive effect for those who see it. The arms of the candleholder are flexible, allowing you to determine its expression for the evening.

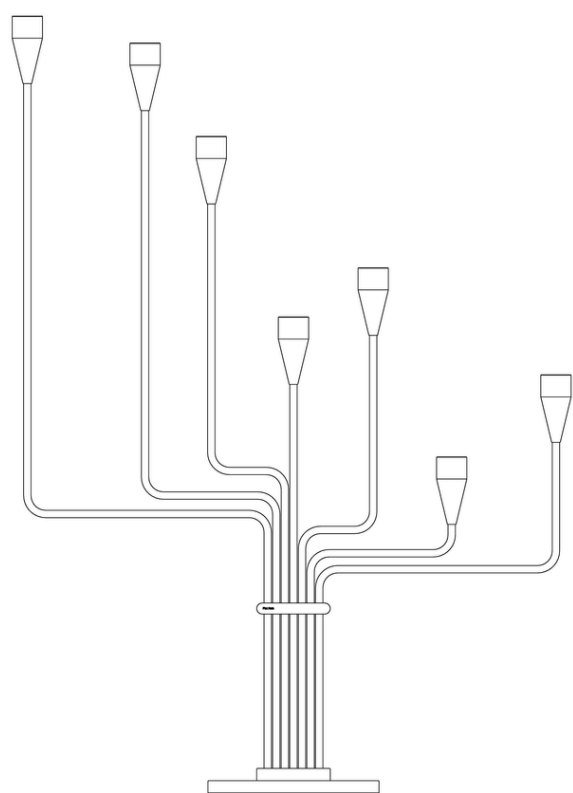

COLOUR

STEEL



LED CANDLES + REMOTE



Piet Hein

LED CANDLES + REMOTE

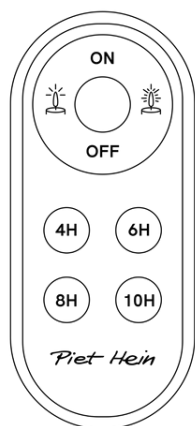

FACTS

LED Candles and a remote made in collaboration with Uyuni Lighting.

SIZE

LED Taper Light - Ø2,3 x 20cm (2 Pack)

LED MAXI Candle - Ø5 x 22cm

Remote - 4 x 10cm

COLOUR

White candles made from virgin parafin wax, with a light grey Piet Hein logo.

Black remote

BACKGROUND

Our new LED candle collection brings a warm, timeless glow to any setting. The slender taper candles add elegance to your table-sized candleholders, creating an inviting atmosphere for dining and gatherings. The larger MAXI candle stands as a stunning centerpiece, casting a gentle, cozy light that draws everyone in. With the convenient remote control, adjusting the ambiance is as easy as a single click, letting you effortlessly set the perfect mood.

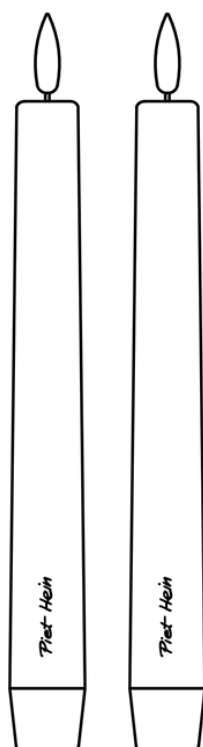
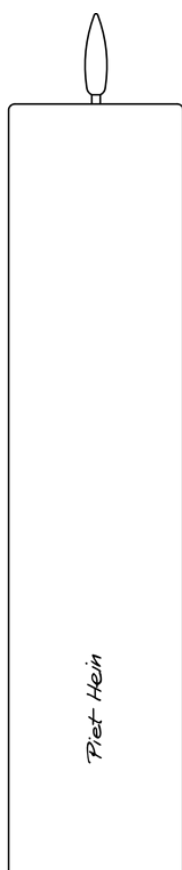

COLOUR

WHITE



SUPER-EGG



Piet Hein

SUPER - EGG

FACTS

Super-egg in solid stainless steel.

SIZE

Height: 3 cm

FARVER

Steel

BACKGROUND

Piet Hein's super-egg is a mathematical invention, but it has also become known as an "anti-stress egg." The small super-egg, made of cool solid stainless steel, fits comfortably in the hand and can be fidgeted with between the fingers or rolled on the table for a playful or stress-relieving purpose. The super-egg comes with a leather pouch for storage.

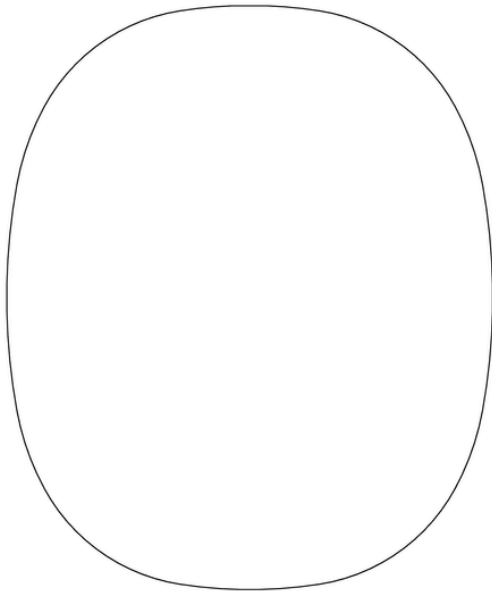

COLOUR

STEEL

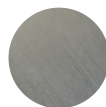

TWINBOWL

SUPER-EGG



Piet Hein

TWINBOWL

FACTS

Made of stainless steel.

SIZES

Small: 7 x 6 cm

Large: 10 x 8,5 cm

COLOUR

Steel

BACKGROUND

The two three-dimensional superellipse halves can be combined or used separately. With the Super-egg, Piet Hein won 2nd place in a design competition held by Georg Jensen. The design was produced by Georg Jensen for a long time, but we are proud to now produce the TwinBowl ourselves, which has so many aesthetic, decorative, and functional qualities.

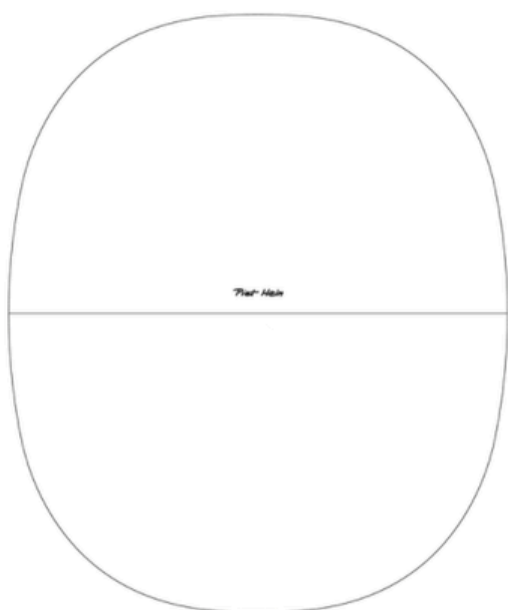

COLOUR

STEEL

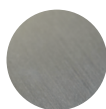

KLABURET



Piet Hein

KLABURET

FACTS

Multi-purpose furniture available in various combinations; laminate and linen or walnut veneer and full-grain leather.

SIZES

Seat height: 42 cm

Seat width: 36cm

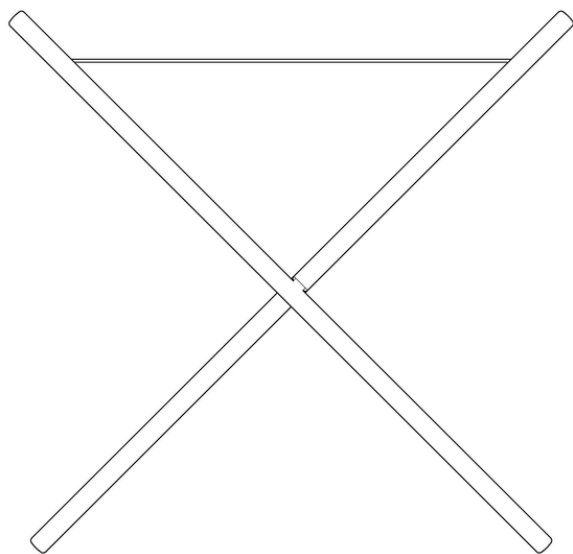

COLOURS

White laminate with linen seat

Black laminate with linen seat

Walnut veneer with natural full-grain leather

Walnut veneer with black full-grain leather

The surface of the white and black klaburets is made of FENIX laminate, which is easy to clean, and scratches can be removed with a damp cloth.

BACKGROUND

The Klaburet unexpectedly appeared in our archive in the form of Piet Hein's own prototype, along with a few very simple product descriptions from 1964, when he put the finishing touches on his idea. The Klaburet is a universal piece of furniture with countless applications. Functionality is the key behind this piece from Piet Hein, which is both designed and produced in Denmark.

COLOURS

WHITE LAMINATE
WITH LINEN



BLACK LAMINATE
WITH LINEN



NATURAL FULL-
GRAIN LEATHER



BLACK FULL-
GRAIN LEATHER



BARSTOOL



Piet Hein

BARSTOOL

FACTS

Designed in 1968

SIZES

Height: 62 cm

Height: 78 cm

MATERIAL

Frame in chrome-plated steel. Upholstered seat in leather.

BACKGROUND

The barstool from Piet Hein, with its span legs and attached footrest, is a piece of furniture designed with high visual beauty, functionality, and comfort in mind. When Piet Hein invented the span leg for the Superellipse table, it was a stroke of genius for its time. Therefore, Piet Hein designed the barstool as a tribute to the unique span leg.

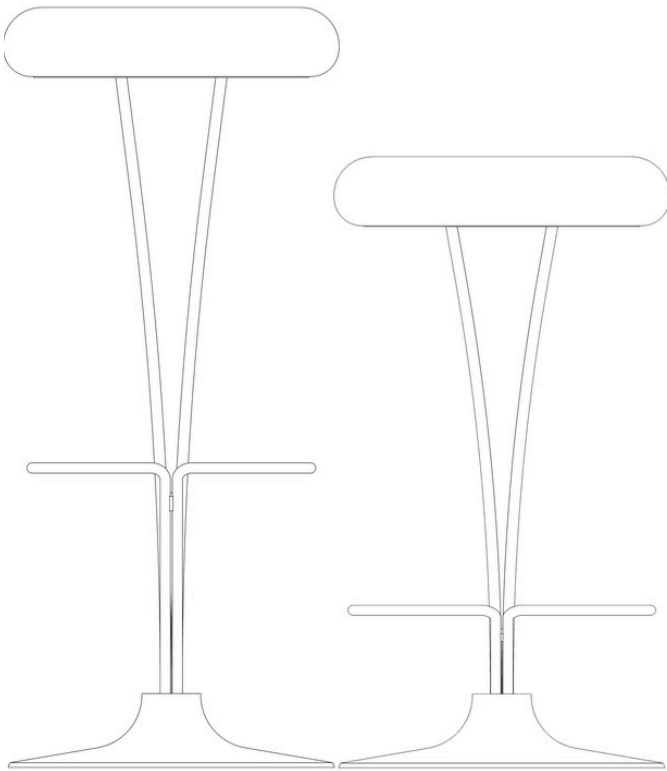

COLOURS

STEEL AND BLACK LEATHER



FLAGPOLES

25CM - 35CM - 50CM - 170CM



Piet Hein

FLAGPOLES

FACTS

Table and floor flagpoles in brushed stainless steel.

SIZES

25 cm - 35 cm - 50 cm - 170 cm

FLAGS

To learn more about the different flags we can provide, visit www.piethein.com or contact us.

BACKGROUND

Need a flag on the table or floor? Piet Hein has created a series of flagpoles perfect for the occasion. The flagpoles feature a Super-egg as the top knob and Piet Hein's smooth Tri-Superellipse as the base. This design provides excellent stability, ensuring you can securely balance it on a tray. The flat base also makes it easy for your local jeweler or engraver to personalize the flagpole with a name, date, or logo.

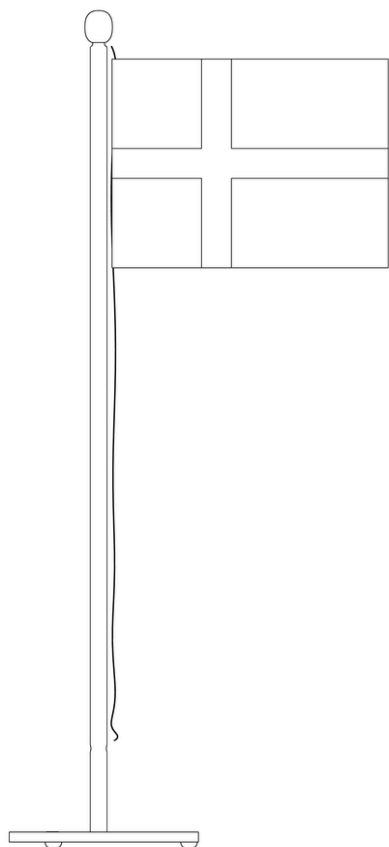

STEEL

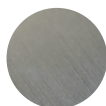

CON-TAC-TIX

GAME



Piet Hein

CON-TAC-TIX

FACTS

Mathematically inspired game invented by Piet Hein.

SIZE

Diagonal dimensions: 56 cm x 32 cm

MATERIAL

Oak

BACKGROUND

Con-Tac-Tix is one of Piet Hein's mathematical highlights, first presented in 1942 at the Niels Bohr Institute. The game, also known as Polygon, was produced by Piet Hein's friend Theodor Skjøde Knudsen during the 1970s in exclusive wood varieties. We are incredibly proud to recreate part of the game series in the same quality but with more sustainable wood.

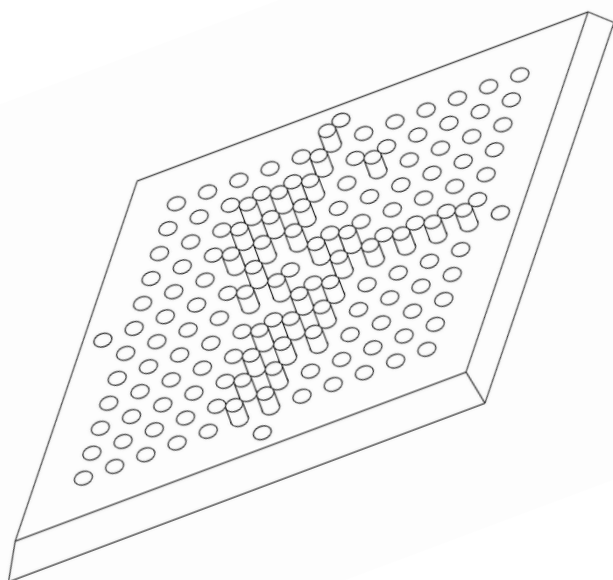

NATURAL OAK



K A L A H A

G A M E



Piet Hein

K A L A H A

FACTS

Made of oak.

SIZE

Height: 3 cm
Width: 25 cm
Length: 47 cm

MATERIAL

Oak
Smoked oak

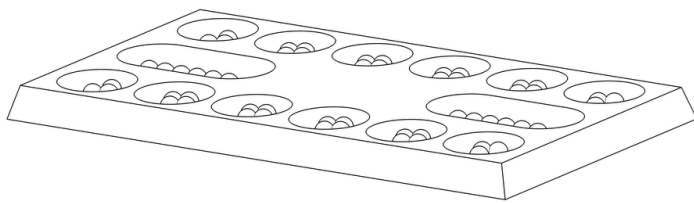

BACKGROUND

In the 1970s, Piet Hein's love for history and games led to a series of games created with Theodor Skjøde Knudsen, a skilled carpenter and friend of Piet Hein. The game series included Piet Hein's own designs as well as classic games that they relaunched in high-quality teak and rosewood. We are incredibly proud to recreate part of this game series in the same quality but with more sustainable wood types.

Kalah, with origins dating back over 7,000 years, has now been revitalized in a beautiful design, allowing the game to be displayed at all times.

NATURAL OAK



SMOKED OAK



S O M A

G A M E

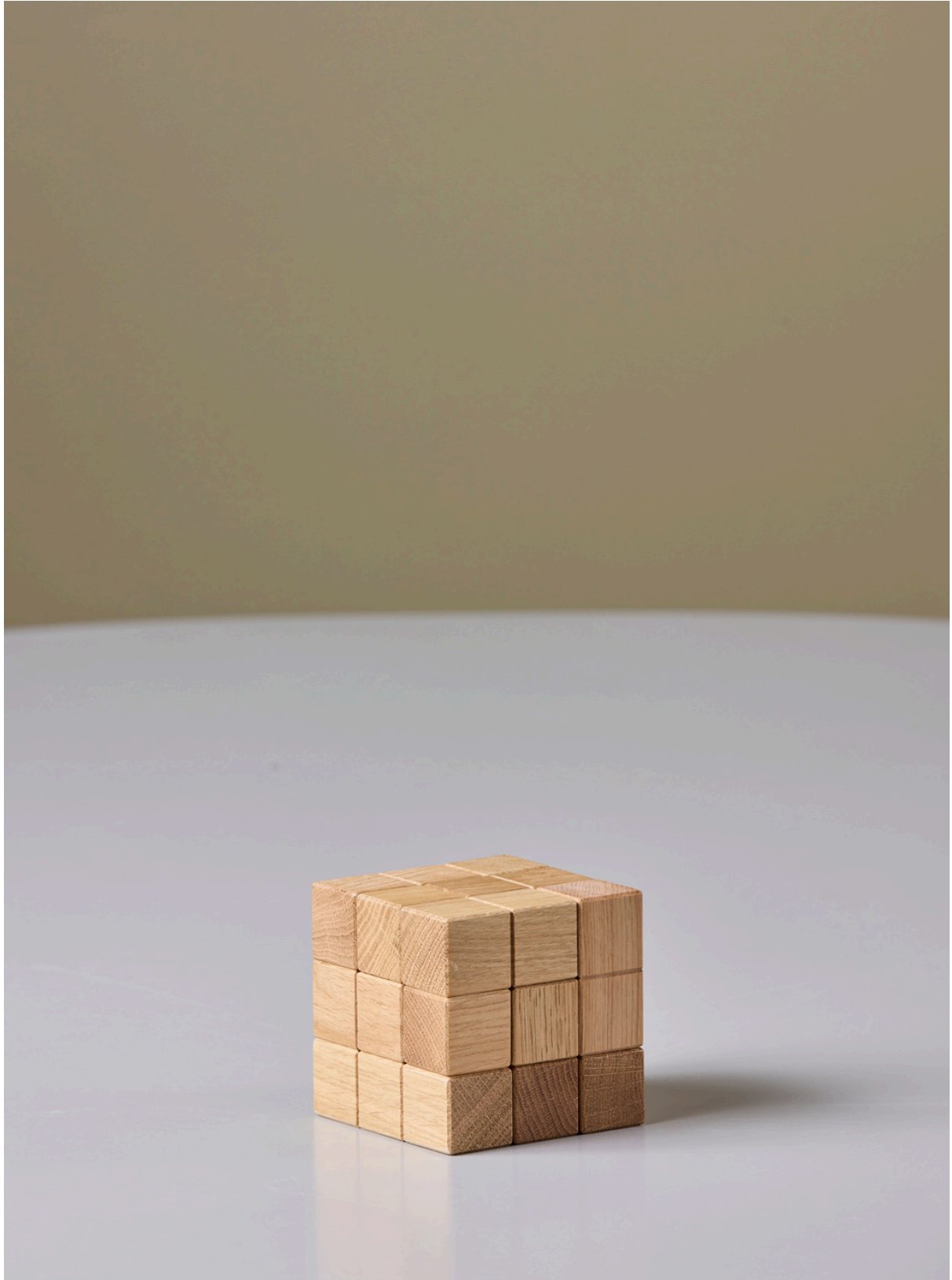

Piet Hein

SOMA

FACTS

Made of oak.

SIZE

8 x 8 x 8 cm

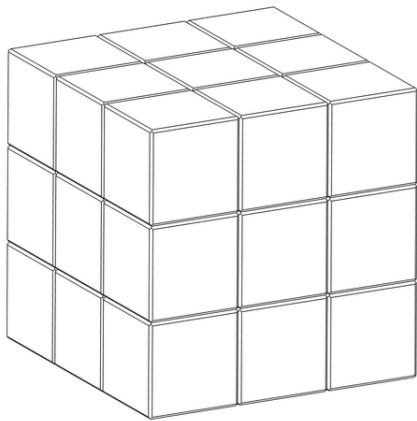

MATERIAL

Oak

HISTORIE

SOMA is one of Piet Hein's mathematical brilliancies that garnered significant international attention. The idea for SOMA came to him in 1933 during a lecture on quantum physics by Werner Heisenberg. While the famous German physicist discussed a space divided into cubes, Piet Hein conceived an extraordinary geometric theory: By taking all the irregular shapes that can be formed by at most four cubes - all of the same size and connected along a lateral face - these shapes could be assembled into a larger cube.

NATURAL OAK



TIC-TAC-TOE

GAME



Piet Hein

TIC - TAC - TOE

FACTS

Made of African teak.

SIZE

Height: 11 cm

Width: 16 cm

Length: 16 cm

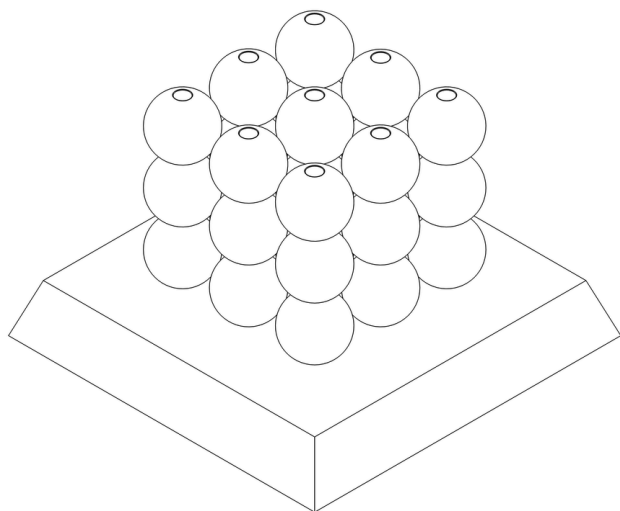

MATERIAL

Dark teak

Maple

Moss oak

BACKGROUND

Piet Hein's love for history and games in the 1970s led to a game series with Theodor Skjøde Knudsen, a skilled carpenter and friend of Piet Hein. The series included Piet Hein's own designs as well as classic games, which they relaunched in high-quality teak and rosewood. We are incredibly proud to recreate part of this series with the same quality but using more sustainable wood types. Tic-tac-toe is a strategic game for two players who take turns placing their markers and try to get three of their own color in a row, horizontally, vertically, or diagonally. The player who achieves this combination the most times is the winner.

DARK TEAK



BOTTLE OPENER

FOR SCREW CAPS AND BOTTLE CAPS



Piet Hein

BOTTLE OPENER

FACTS

Made of stainless steel.

SIZE

Diameter: 12,5 cm

MATERIAL

Stainless Steel

BACKGROUND

For Piet Hein, design was about seamlessly integrating aesthetics and functionality. If the design could also solve a problem, regardless of its size, then he considered it a success. The circular bottle opener combines the ability to open bottle caps and easily loosen screw caps, thanks to the ribbed hole in the center of the opener.

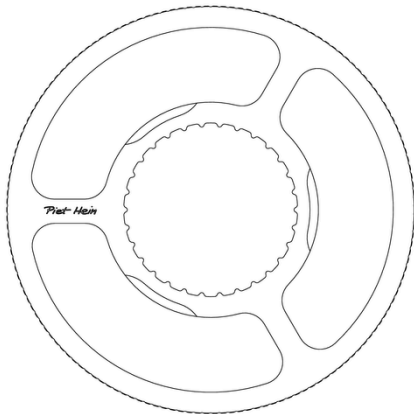
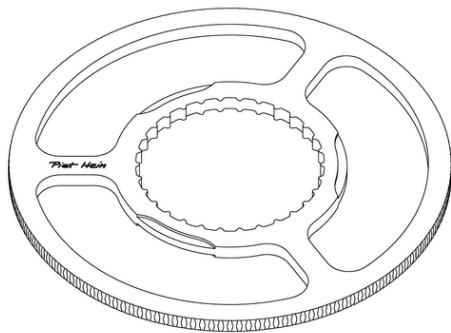

STEEL

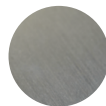

WOODEN TRAYS

NATURAL AND SMOKED OAK



Piet Hein

WOODEN TRAYS

FACTS

Superelliptical wooden tray. Produced in Denmark.

SIZE

Superelliptical tray
Length: 41 cm
Width: 34 cm

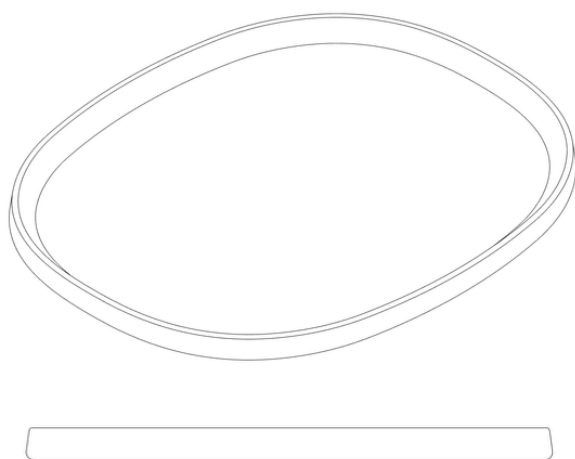

MATERIAL

Natural oak or smoked oak

BACKGROUND

The tray was first put into production by Kay Bojesen in the early 1960s with a design by Piet Hein. Back then, it was made of teak, while this tray is made of oak, which gives it a sense of lightness and elegance.

The tray is not dishwasher safe; it should only be wiped clean with a damp cloth. Not suitable for hot items, as they may damage the natural wood. By maintaining the tray with regular neutral oil, you can ensure it lasts for many years, while continuing the legacy of the remarkable superellipse® design.

COLOURS

NATURAL OAK



SMOKED OAK



STEEL TRAY

POLISHED STAINLESS STEEL



Piet Hein

STEEL TRAY

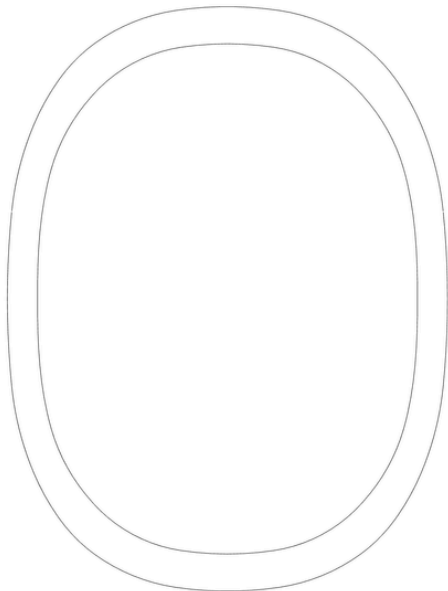
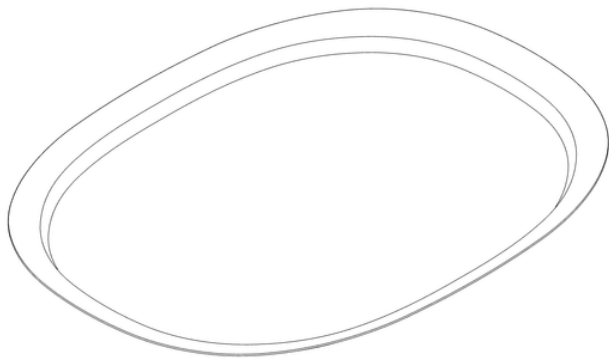

FACTS

Superelliptical tray in mirror polished stainless steel.

SIZE

16,5 x 12 cm
31 x 41 cm

MATERIAL

Stainless steel

BACKGROUND

Piet Hein's trays in mirror polished stainless steel are designed with inspiration from the Superellipse, which played a significant role in making him world-famous. Piet Hein created the initial versions of the steel trays in collaboration with silversmith Georg Jensen, who produced several of his designs in brass, silver, and steel.

STEEL



DRINKING GLASSES

WITH PIET HEIN'S GROOKS



Piet Hein

DRINKING GLASSES

FACTS

2-pack drinking glasses with Piet Hein's Grooms - available in 3 versions:

1. "Husk at elske..." & "Af mad på fad..."
2. "Hvis du ingen..." & "Husk de tre..."
3. "Undfly alle..." & "Fagfolk har man..."

SIZE

25 cl

MATERIAL

Clear glass

BACKGROUND

A small selection of Piet Hein's recognizable and wise Grooms has been brought to life in our series of drinking glasses.

These glasses reflect Piet Hein's genius in language, with each glass featuring a Groom printed in both Danish and English.

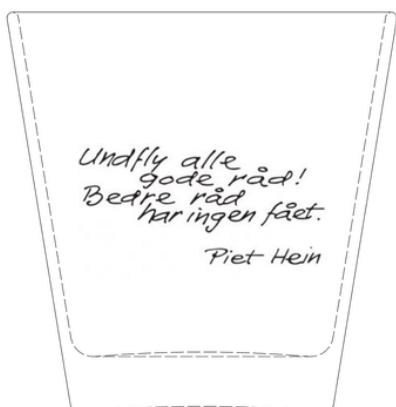

CLEAR



DISHES

PORCELAIN



Piet Hein

PORCELAIN DISHES

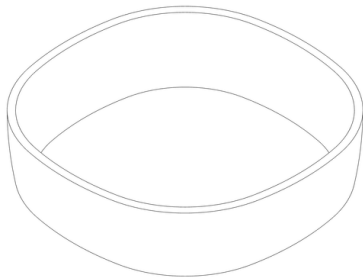
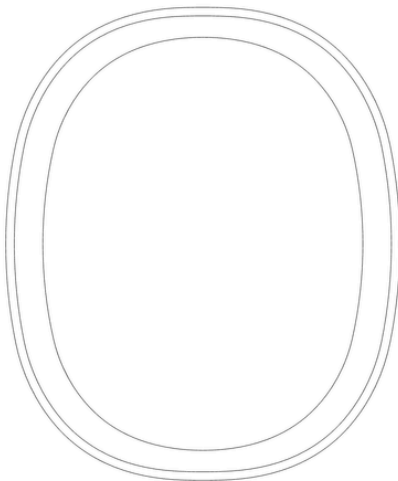
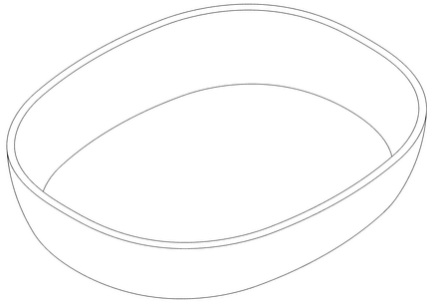

FACTS

Ovenproof dishes made of porcelain

SIZES

11 x 15 x 5 cm
15 x 20 x 5,5 cm
19 x 25 x 6,5 cm
26 x 26 x 7 cm
27 x 35 x 7,5 cm

COLOURS

White
Black

BACKGROUND

The porcelain dishes are designed by Piet Hein based on the Superellipse, with a focus on creating a series of multifunctional dishes.

These ovenproof dishes can be used for serving cold dishes, heating food in the microwave, freezing, and cooking your dishes in the oven. The dishes are stackable across sizes to minimize storage space.

COLOURS

WHITE



BLACK



GLASS BOWLS

BLACK - OPAL - CLEAR GLASS



Piet Hein

GLASS BOWLS

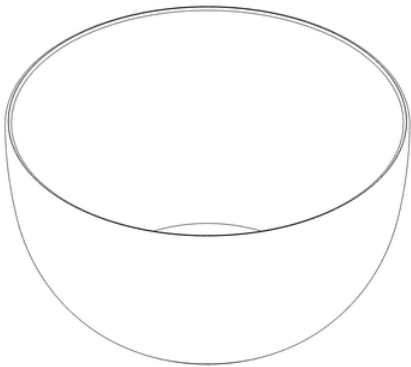

FACTS

Glass bowl created with inspiration from the Superellipse.

SIZES

Diameter:
10 cm, 14 cm, 18 cm, 21 cm, 26 cm



COLOURS

Opal
Black
Clear

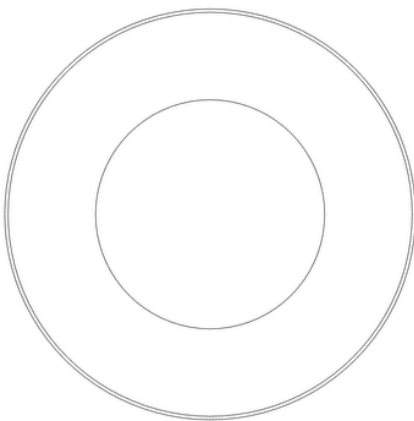

BACKGROUND

Piet Hein's love for the Superellipse and its functionality inspired this series of glass bowls, which combine quality materials with the unique shape of the Superellipse. Piet Hein's focus on functionality resulted in a series of bowls designed for various purposes, stackable across sizes to minimize storage space.

COLOURS

OPAL



BLACK



CLEAR

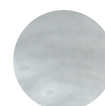

BOWLS

PORCELAIN



Piet Hein

PORCELAIN BOWLS

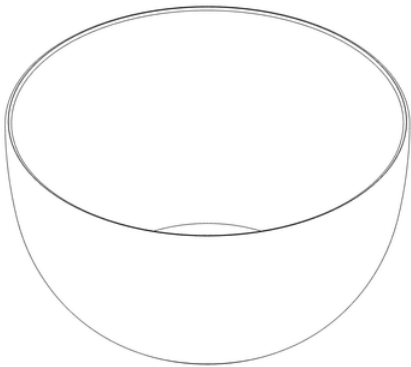

FACTS

Porcelain bowls created with inspiration from the Superellipse.

SIZES

Diameter:
10 cm, 14 cm, 18 cm, 21 cm, 26 cm



COLOURS

White
Black

BACKGROUND

Piet Hein created this series of porcelain bowls inspired by the Superellipse. The bowls are simple, elegant, and the porcelain material allows them to be used for storage, preparation, and serving. When not in use, the bowls can be stacked across sizes to minimize space.

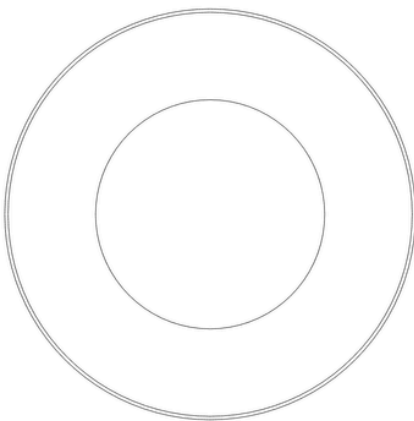

COLOURS

WHITE



BLACK



BOWLS

STAINLESS STEEL



Piet Hein

STAINLESS STEEL BOWLS

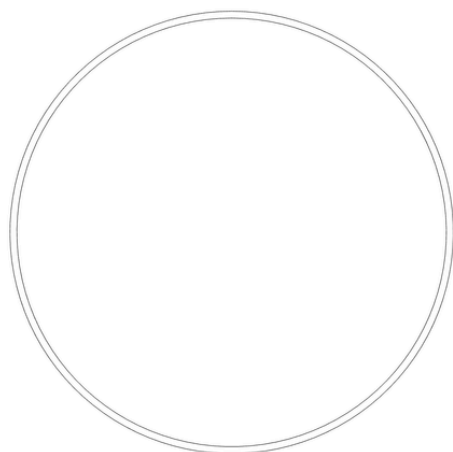
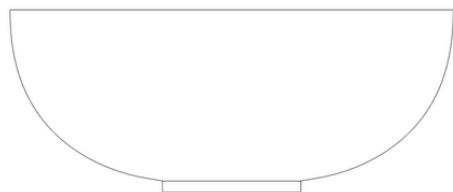
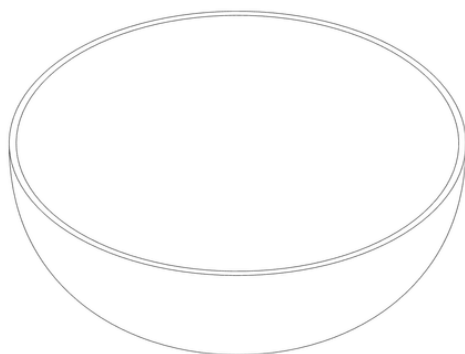

FACTS

Bowls made of stainless steel.

SIZES

Diameter:
8 cm, 10,5 cm, 13 cm, 15,5 cm, 18 cm, 30 cm

COLOUR

Steel

BACKGROUND

Piet Hein's early collaboration with Georg Jensen also resulted in a line of steel bowls that he designed with inspiration from the Superellipse. These bowls are now part of our own production, maintaining the high quality that is key to this series.

STEEL



PLATES

PORCELAIN



Piet Hein

PLATES

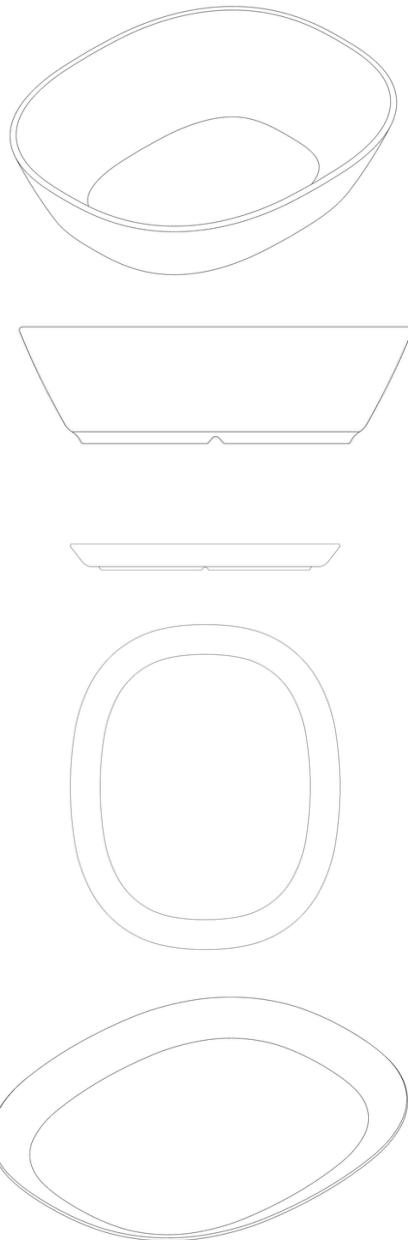

FACTS

Porcelain plate series

SIZES

Deep plate:
15 x 18 cm

Dessert plate:
16 x 19 cm with plateau
16 x 19 cm

Lunch plate:
20 x 24 cm with plateau
20 x 24 cm

Dinner plate:
25 x 30 cm with plateau
25 x 30 cm

COLOURS

White
Black

BACKGROUND

Piet Hein's love for the Superellipse is evident in his plates. The Superelliptical shape breaks away from the classic round plate, offering new possibilities for presentation. Piet Hein incorporated several functional elements into his design, making the plates easy to stack when serving multiple dishes or clearing the table.

COLOURS

WHITE



BLACK



SALT AND PEPPER SET

STEEL SHAKERS



Piet Hein

SALT AND PEPPER STEEL SHAKERS

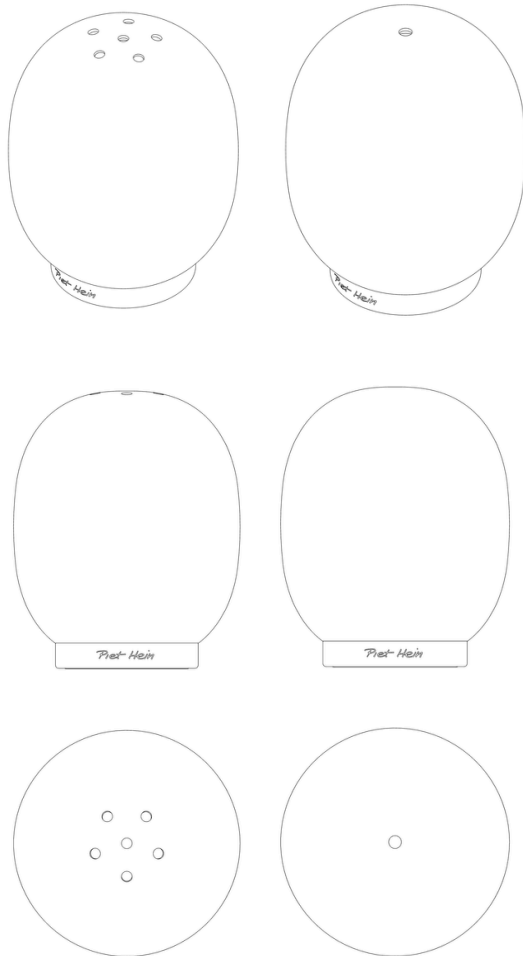

FACTS

Salt and pepper steel shakers

SIZE

Height: 4,5 cm

MATERIAL

Stainless steel

BACKGROUND

The salt and pepper shakers are made of stainless steel and inspired by the Super Egg, which is the three-dimensional version of Piet Hein's Superellipse®.

The salt and pepper set features a minimalist design that discreetly yet elegantly enhances the table setting.

STEEL

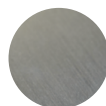

SALT AND PEPPER SET

STEEL GRINDERS



Piet Hein

SALT AND PEPPER GRINDERS

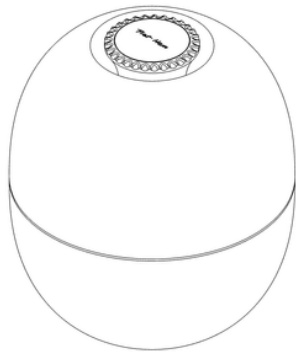

FACTS

Salt and pepper grinders

SIZE

Height: 7,5 cm

MATERIAL

Steel

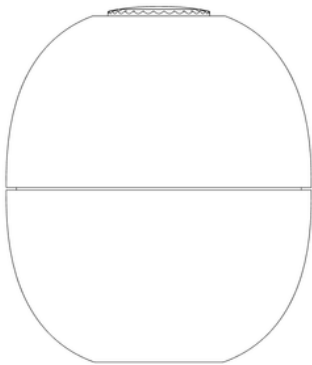

BACKGROUND

Piet Hein's salt and pepper grinders are made of stainless steel and inspired by the Super Egg, which is the three-dimensional version of the Superellipse®. Piet Hein designed the salt and pepper grinders with the functionality of having the adjustable grinder located at the top of the product. This design helps prevent residue on your table and allows you to easily adjust the coarseness of the spices.

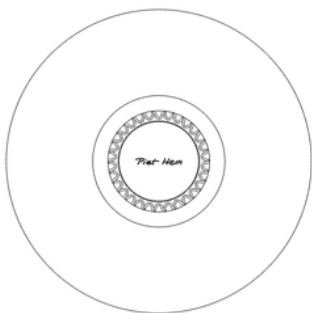

STEEL

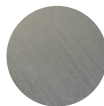

CUTTING BOARDS & CHOPPING BLOCK

TEAK



Piet Hein

CUTTING BOARDS & CHOPPING BLOCK

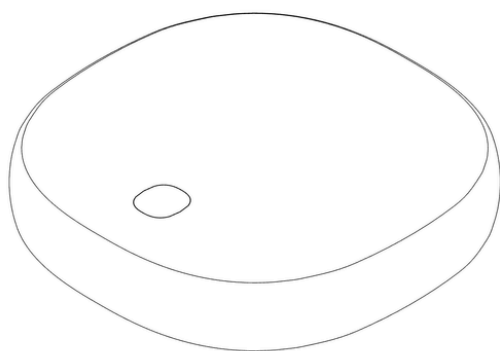
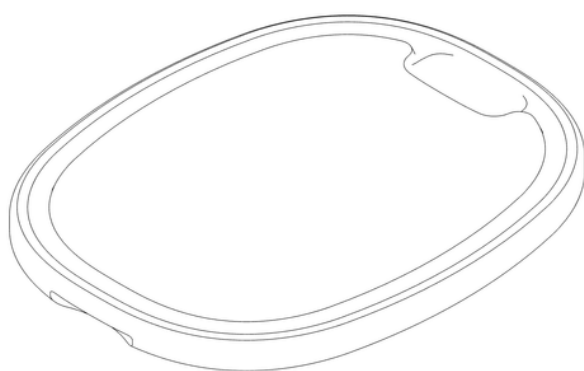

FACTS

Cutting board series in teak.

SIZES

Supercircular chopping block 26 x 5 cm
Superellipse cutting board 35 x 28 x 3 cm
Superellipse cutting board 45 x 36 x 3 cm

MATERIAL

Teak

BACKGROUND

Piet Hein's interest in mathematics and geometry contributed to making the Superellipse one of his superb designs. In the context of kitchenware, this is reflected in this series of cutting boards, which combine the shape of the Superellipse® with teak wood.

COLOUR

TEAK

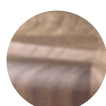

NORDLYS
DENMARK

BIO FIREPLACE



Piet Hein

NORDLYS DENMARK

FACTS

Bio Fireplace inspired by the Superellipse.

SIZE

H66 x B80 x D16 – 33 kg

COLOURS

Available in six versions.

Frame in Black, White or Forrest Green.

With a wooden front of Oak or Walnut.

BACKGROUND

Introducing the Superellipse Bio Fireplace, inspired by Piet Hein's iconic shape. This elegant piece blends timeless aesthetics with contemporary function, featuring the unique, harmonious curves of the superellipse. Its captivating form becomes the focal point of any room, radiating warmth and modern sophistication. Transform your space with this statement of refined elegance and innovative design.

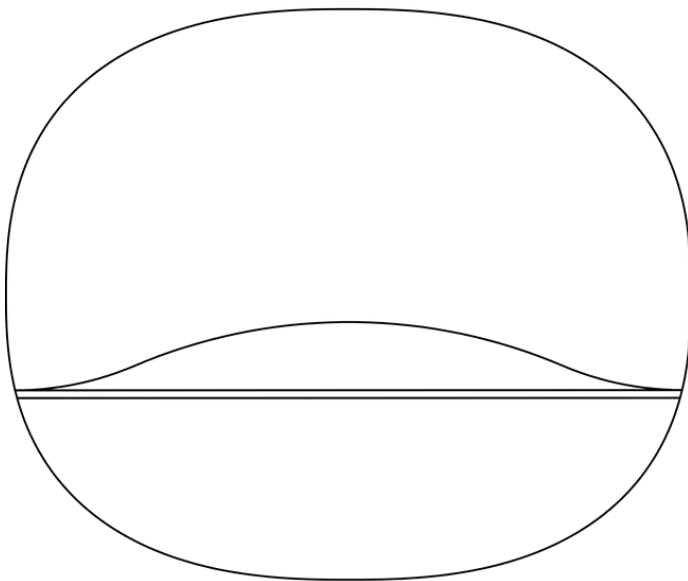

FRITZ HANSEN

SUPERELLIPSE TABLE



Piet Hein

FRITZ HANSEN

FACTS

Table inspired by the Superellipse.

SIZES

Available in multiple sizes with the option for extension leaves.

For more information, contact Fritz Hansen:

+45 4817 2300

info@fritzhanzen.com

COLOURS

Several variations available.

Visit Fritz Hansen's website:

www.fritzhanzen.com

BACKGROUND

The iconic Superellipse table, created in collaboration with Bruno Mathsson and produced by Fritz Hansen since 1968. After Piet Hein applied the Superellipse to solve a traffic challenge at Sergels Torg in Stockholm, he saw numerous possibilities for its application. The table showcases Piet Hein's skill as a furniture designer, as he not only designed the tabletop but also the iconic span legs.



Stilling

SINCE 1949

CURTAIN TRACK



Piet Hein

STILLING

FACTS

Aluminium. 12 pcs. roller gliders per meter, ceiling brackets. Optional wave gliders, CURVE or SQUARE design brackets, as well as LED lights.

SIZES

It's delivered as a complete set according to measurements. For more info, contact Stilling: stilling@stilling.dk
+45 4360 0063

COLOURS

The rail is available in 4 colours, all matching Piet Hein's Superellipse® table: Snow, Midnight, Stone, Sand. Additionally, it can be delivered in any RAL color for an extra charge.

BACKGROUND

The world's first Superellipse® curtain rail has been unveiled. This rail is shaped in cross-section like Piet Hein's geometric figure and features his logo. As an additional exclusive feature, the curtain rail includes a LED track. Now, you can enjoy both the beauty of the curtain track and your curtain fabric even in the dark.

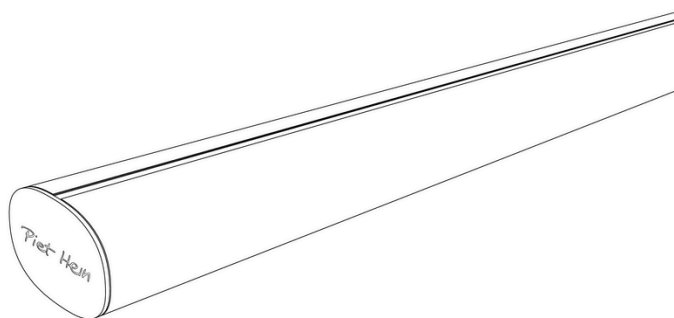

COLOUR OPTIONS

SAND



SNOW



STONE



MIDNIGHT



CHAIRS



Piet Hein

SIBAST

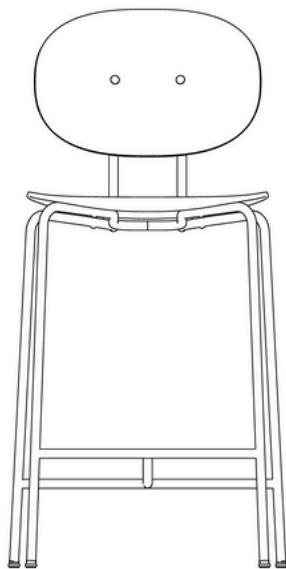
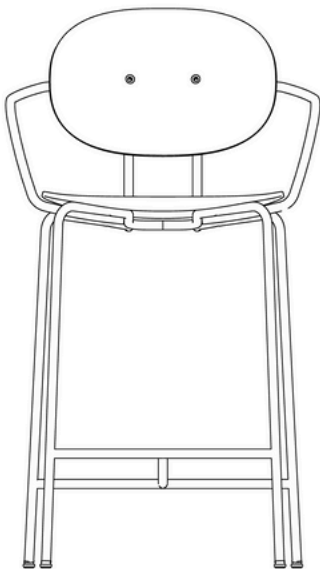
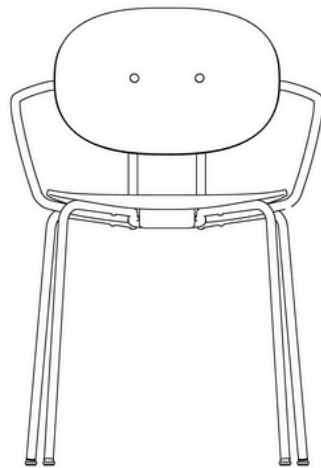
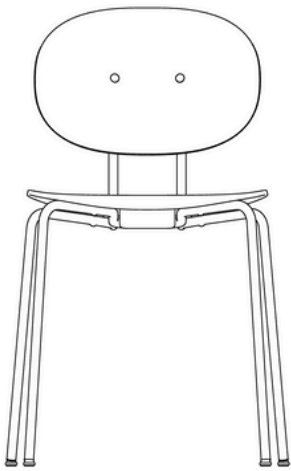

FACTS

Design collaboration between Piet Hein and Sibast. Originally designed by Piet Hein in 1968.

SIZES

Dining chair

Height: 80 cm Seat height: 45 cm

Bar stool

Low - Height: 98 cm Seat height: 65 cm

High - Height: 108 cm Seat height: 75 cm

COLOURS

Frame available in black or chrome.

The chair is Custom Design, where you can choose between a seat and backrest in wood or upholstered with leather, textile or wool.

BACKGROUND

Piet Hein developed the chair based on the superellipse, a shape he originally conceived for a combined city square and roundabout at Sergels Torg in Stockholm. Using mathematics, Piet Hein arrived at a harmonious geometric form which he subsequently used in various contexts.

The superelliptical chair and barstool stand as fine examples of Piet Hein's approach to imagining form and function. His ability to distill to the essence, both in words and physical materials, is undeniable, perhaps explaining why the chairs still appear refreshingly modern today.

RUGS



Piet Hein

ALMEDAHL S

FACTS

Design collaboration between Piet Hein and Almedahls. Uniquely designed carpets inspired by the superellipse.

SIZES

Available in 5 formats:

3:6

4:6

5:6

6:6

Tri Superellipse®

COLOURS

The carpet is available in 140 different standard colours as well as 22 Designers Choice editions.

BACKGROUND

AVGO is an innovative and versatile carpet collection created in collaboration between Piet Hein and Almedahls. The carpet features a technical solution that creates a two-tone effect using only one color. On the edge, there is a symbol of the 4:6 Superellipse®.

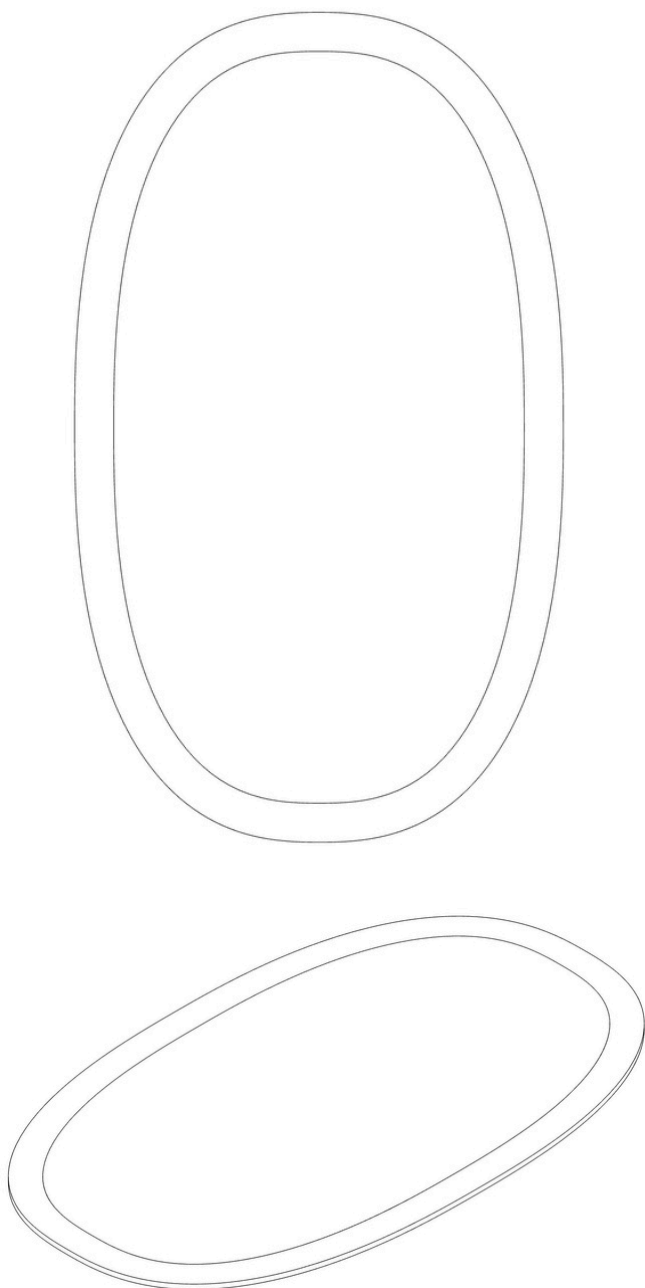

almedahls

CURTAINS



Piet Hein

ALMEDAHL S

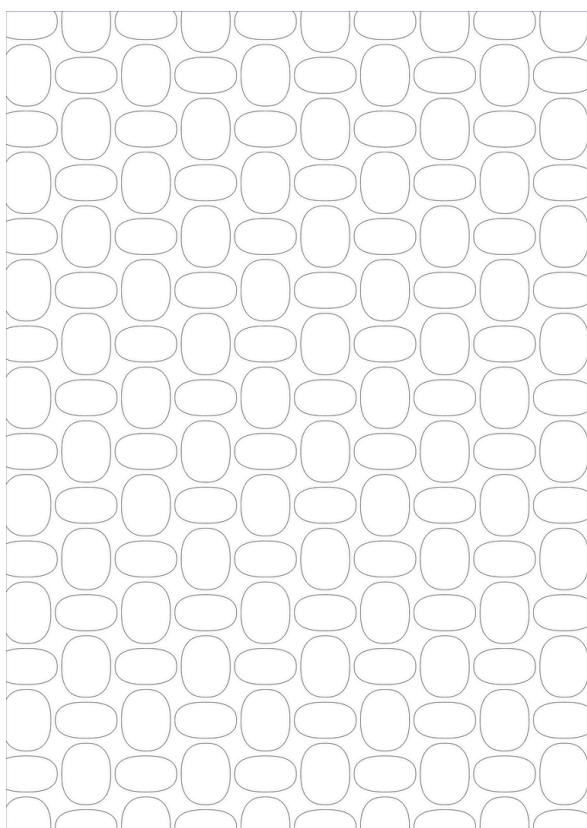

FACTS

Collaboration between Piet Hein and Almedahls. Uniquely designed curtains inspired by the Superellipse.

SIZES

The curtain is produced according to the customer's desired measurements. For more information, contact Almedahls at stilling@almedahls.se
Phone: +45 4057 4703

COLOURS

The curtains are produced in five subdued colours. For more information, visit Almedahls' website at www.almedahls.se

BACKGROUND

Inspiro is a series of curtain textiles created in collaboration between Piet Hein and Almedahls. The series is based on Piet Hein's Superellipse® and the textile is designed to shield from direct sunlight while creating bright and inspiring spaces, a quality reminiscent of Piet Hein's exploration of lamps and lighting.

MAKE

STOOLS



Piet Hein

MAKE NORDIC

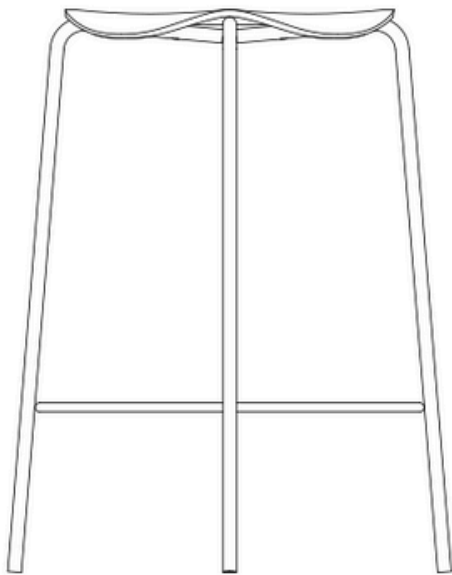

FACTS

Stool and bar stool designed by Piet Hein.
Produced and sold by Danish MAKE Nordic.

SIZES

Stool - Height: 45cm
Barstool - Height: 65cm
Barstool - Height: 75cm

MATERIALS

Black powder-coated steel frame.
Seat made of oak or leather upholstered.

BACKGROUND

Piet Hein's Superellipse® is the basic shape in this design, which can be traced back to 1968. The supercircle forms the seat in all variants and also serves as a footrest on the two bar stools.

The classic minimalism seen in several of Piet Hein's designs is also evident in this series of stools from MAKE nordic.

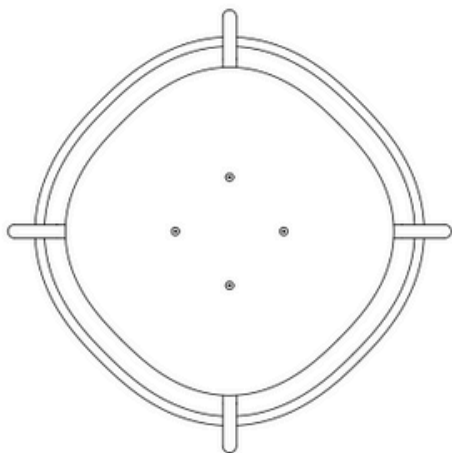

DESIGN PARTNERS

CONTACT

FRITZ HANSEN

Contact Fritz Hansen for more information.

@: info@fritzhanzen.com

Tlf.: +45 4817 2300

STILLING

Contact Stilling for more information.

@: stilling@stilling.dk

Tlf.: +45 4360 0063

SIBAST

Contact Sibast for more information.

@: info@sibast-furniture.com

Tlf.: +45 2279 7750

ALMEDAHL'S

Contact Henrik Stilling for more information.

@: stilling@almedahls.se

Tlf.: +45 4057 4703

MAKE NORDIC

Contact Make Nordic for more information.

@: info@makenordic.com

Tlf.: +45 2910 3800

Piet Hein

PIET HEIN TRADING APS
MANDALVÆNGET 5
5500 MIDDELFART
DANMARK

+ 45 63 40 40 80
INFO@PIETHEIN.COM

ACCESS OUR CATALOGUES ONLINE

