

Piet Hein

LIGHTING COLLECTION





Love while you've got
love to give.
Live while you've got
life to live.

SUPER EGG

150 - 200 - 300



Piet Hein

SUPER EGG

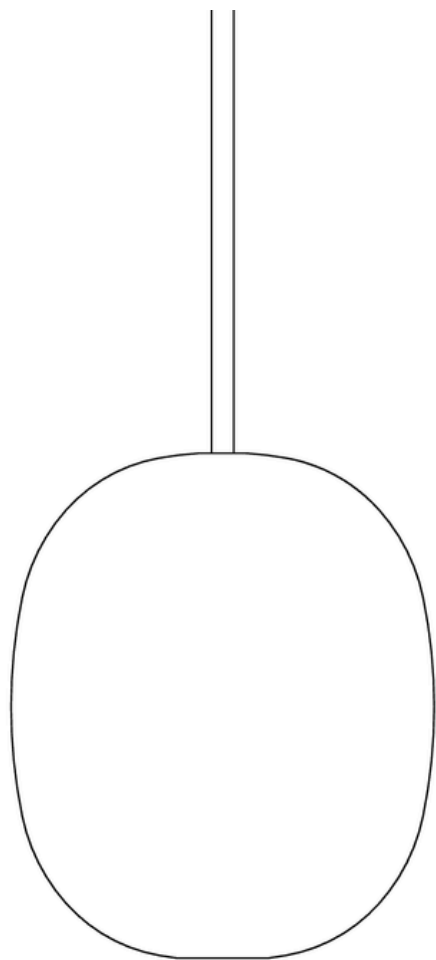

FACTS

Mouth-blown opal glass with 3 metres of fabric cord.

SIZES

150P - H: 150mm, Ø:125mm, Max 42W G9
200P - H: 200mm Ø:168mm, Max 42W G9
300p - H: 320mm, Ø: 250mm, Max 105W E27

COLOURS

Opal glass with optional coloured fabric cord in red, white or black.

BACKGROUND

The Superegg lamp, designed by Piet Hein, is inspired by his iconic Superellipse®. The lamp is almost closed at the bottom, which hides both the bulb and the socket, making the Superegg a luminous, artistic element in the decor. The simplicity and soft light of the Superegg make the lamp ideal for hanging in virtually any location in the home. Beautifully shaped over the pure geometric form of the Superellipse®.

CORD COLOUR

WHITE



BLACK



RED



SUPERCUBE

150 - 200



Piet Hein

SUPERCUBE

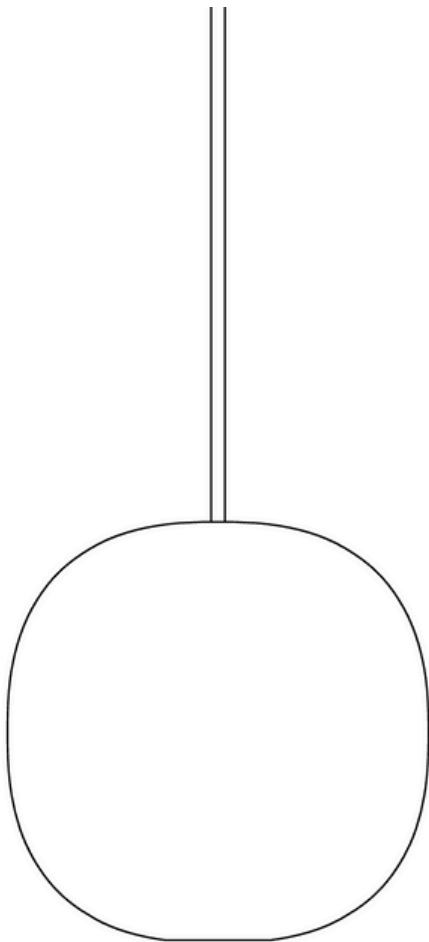

FACTS

Mouth-blown opal glass with 3 metres of fabric cord.

SIZES

150P - H: 150mm, Ø:150mm, Max 42W G9
200P - H: 200mm Ø:200mm, Max 42W G9

COLOURS

Opal glass with optional coloured fabric cord in white or black.

BACKGROUND

The Supercube, like the Superellipse®, is an example of Piet Hein's interest in design and geometry. The Supercube is the three-dimensional version of the Supercircle, which is based on the same formula as the Superellipse. If the shape seems familiar, it may be because Fritz Hansen produces a table based on the same design by Piet Hein.

CORD COLOUR

WHITE



BLACK



BEEHIVE

180 - 290



Piet Hein

BEEHIVE

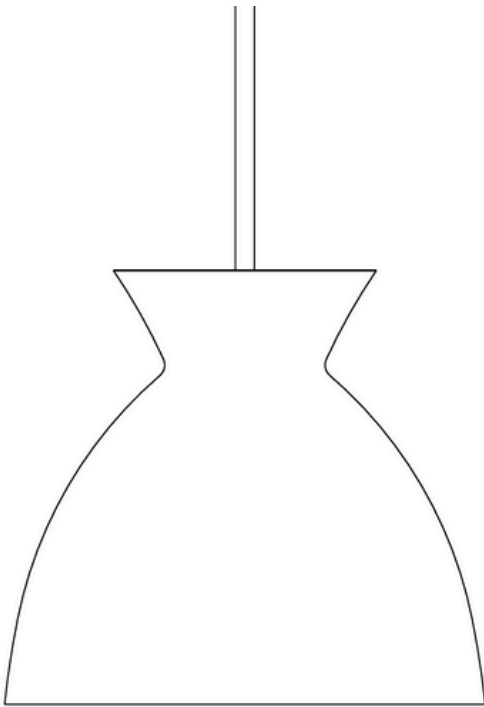

FACTS

Mouth-blown opal glass with 3 metres of fabric cord.

SIZES

180P - H: 160mm, Ø:177mm, Max 40W E14
290P - H: 260mm Ø:288mm, Max 40W E27

COLOURS

Opal glass with optional colour fabric cord in white or black.

BACKGROUND

The Beehive lamp was created in 1979 as a proposal from Piet Hein for lighting over tables and workspaces in a bank with the same name (Bikuben). The lamp was never put up for sale and was only launched in 2018 as part of our range of lighting products. The Beehive lamp features a design inspired by the natural structure of a beehive, while also taking into account both light quality and aesthetics at the same time.

CORD COLOUR

WHITE



BLACK



FLORA FOLIO



Piet Hein

FLORA FOLIO

FACTS

Lacquered aluminium shades; matte white on the inside and semi-glossy on the outside. Mounted on extruded aluminium arms.

SIZE

H: 650mm Ø:600mm, Max 200W E27

COLOURS

White with 6 metres of black fabric cord.

BACKGROUND

Flora Folio is an unusually beautiful pendant for larger spaces, designed by Piet Hein in 1969. Much like a large flower, the shade petals unfold gracefully, creating on one side the beautiful characteristic shape and on the other side the perfect reflection of light. The white screens, which are matte on the inside and semi-glossy on the outside, are mounted on extruded superelliptical aluminum rods. A luminous unicum.

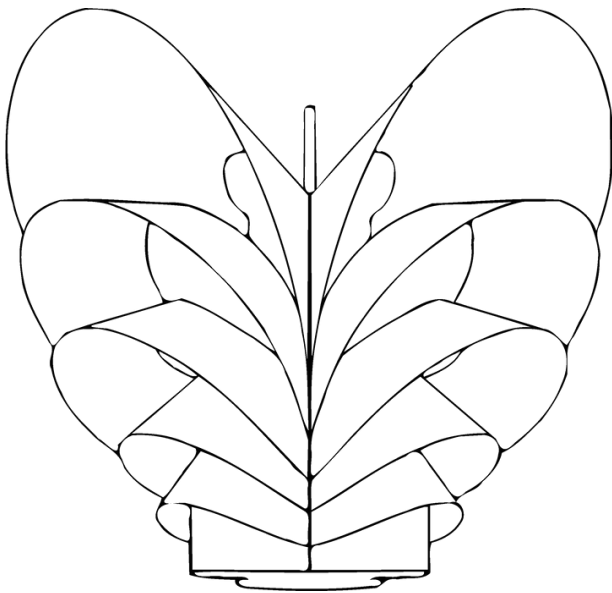

CORD COLOUR

BLACK



FUNCO



Piet Hein

FUNCO

FACTS

White canvas shade with a reflecting inner surface. Stainless steel base.

SIZES

H: 550mm Ø: 320mm

Base: Ø:220mm Max 20W E27

COLOURS

White shade with 2.3 metres of black fabric cord.

BACKGROUND

Designed by Piet Hein in 1933, Funco was first showcased at the Inventors' Spring Exhibition in 1934. The shade can be rotated as needed, allowing the lamp to spread light in the desired direction. The material composition of the shade also means that Funco is simply white when the lamp is off, while it acquires a beautiful and vibrant, two-tone colour when the bulb is on. Featuring a Superegg-inspired on/off switch, and the geometric rounding of the base, which cleverly conceals a black fabric cord, complete this classic.

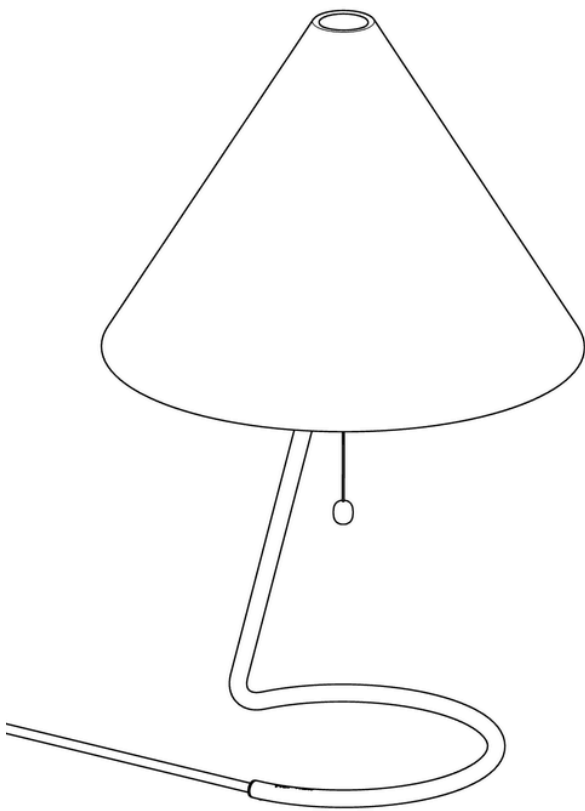

CORD COLOUR

BLACK



SUPER

90 - 115 - 215



Piet Hein

SUPER

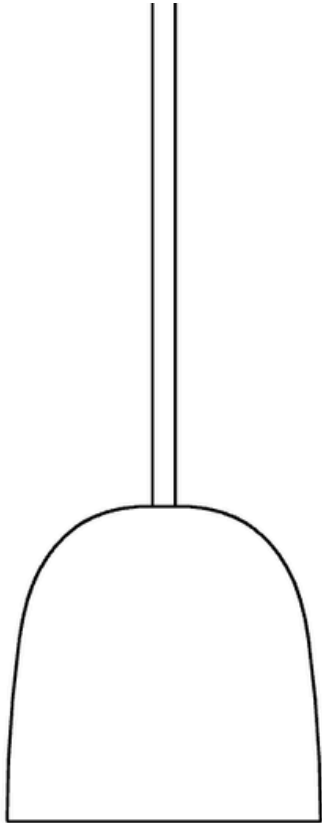

FACTS

Frosted glass with 3 metres of fabric cord.

SIZES

90p - H: 93mm, Ø:90mm, Max 42W G9

115P - H: 119mm Ø:115mm, Max 42W G9

215p - h:174mm, Ø:216mm, Max 60W E27

COLOURS

Frosted glass with optional colour of fabric cord in red, white, or black. Super 215 is also available with a white metal shade.

BACKGROUND

Designed in 1975, Piet Hein's play with geometry, particularly curves that could break and reflect light, resulted in the lamp with the exciting name. The lamp's combination of the open base and the diffusing opal glass creates an intense light cone beneath the lamp, while offering optimal, glare-free illumination throughout the space.

CORD COLOUR

WHITE



BLACK



RED



SINUS

330 - 440 - 550



Piet Hein

SINUS

FACTS

Frosted, white opal glass. Includes 4 metres of fabric cord and a Ø11 cm canopy to cover the LED transformer.

SIZES

330P - H:70mm, Ø:330mm, LED 7,5 Watt
440P - H:78mm, Ø:440mm, LED 10,5 Watt
550P - H:79mm, Ø:550mm, LED 10,5 Watt

COLOURS

Frosted opal glass with a white fabric cord.

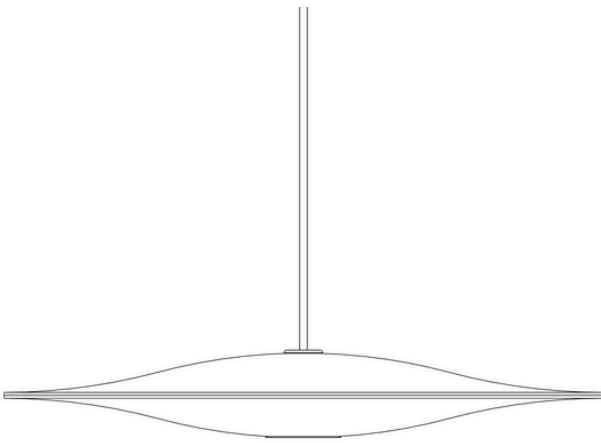

BACKGROUND

When Piet Hein designed the Sinus lamp in 1967, the goal was to create a lamp based on the sinus curve. This choice was made not only because it's a mathematically harmonious form but also because it's technically ideal for lighting. The lamp's curved shapes ensure that the light is strong precisely where it needs to be, while the light directed towards the eye and the surrounding space is glare-free and exceptionally beautiful. Sinus ensures the perfect light, while the shade itself stands as a floating, sculptural form in the room.

CORD COLOUR

WHITE

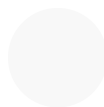

SINUS WOOD

WALNUT - OAK



Piet Hein

SINUS WOOD

FACTS

The classic Sinus Lamp, but with an upper shade of 3D veneer. Designed in collaboration with designer Philip Bro Ludvigsen.

SIZES

550P - H:79mm, Ø:550mm, LED 10,5 Watt

COLOURS

Upper part made of walnut or oak with lower shade of white frosted glass and a creme-white fabric cord.

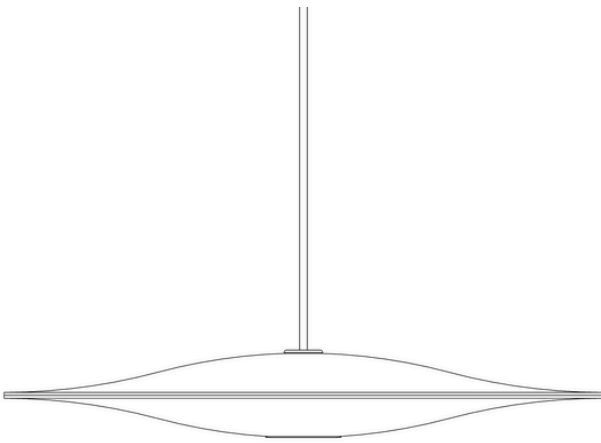

BACKGROUND

Sinus Wood is inspired by Piet Hein's iconic sinus lamp from 1967. It retains the mathematical characteristics of the sinus curve to ensure optimal lighting where it is most needed, while also being gentle on the eyes without causing glare. With an upper part made of wood, the lamp radiates warmth and inviting aesthetics, fitting perfectly into the Nordic style where wood often dominates in interior design. Created by Philip Bro Ludvigsen and Piet Hein, Sinus Wood combines classic lamp architecture with a modern expression.

MATERIAL ON UPPER PART

WALNUT



OAK



Piet Hein

PIET HEIN TRADING APS
MANDALVÆNGET 5
5500 MIDDELFART
DANMARK

+ 45 63 40 40 80
INFO@PIETHEIN.COM

ACCESS OUR CATALOGUES ONLINE

